

Installation, Operation, & Maintenance Manual

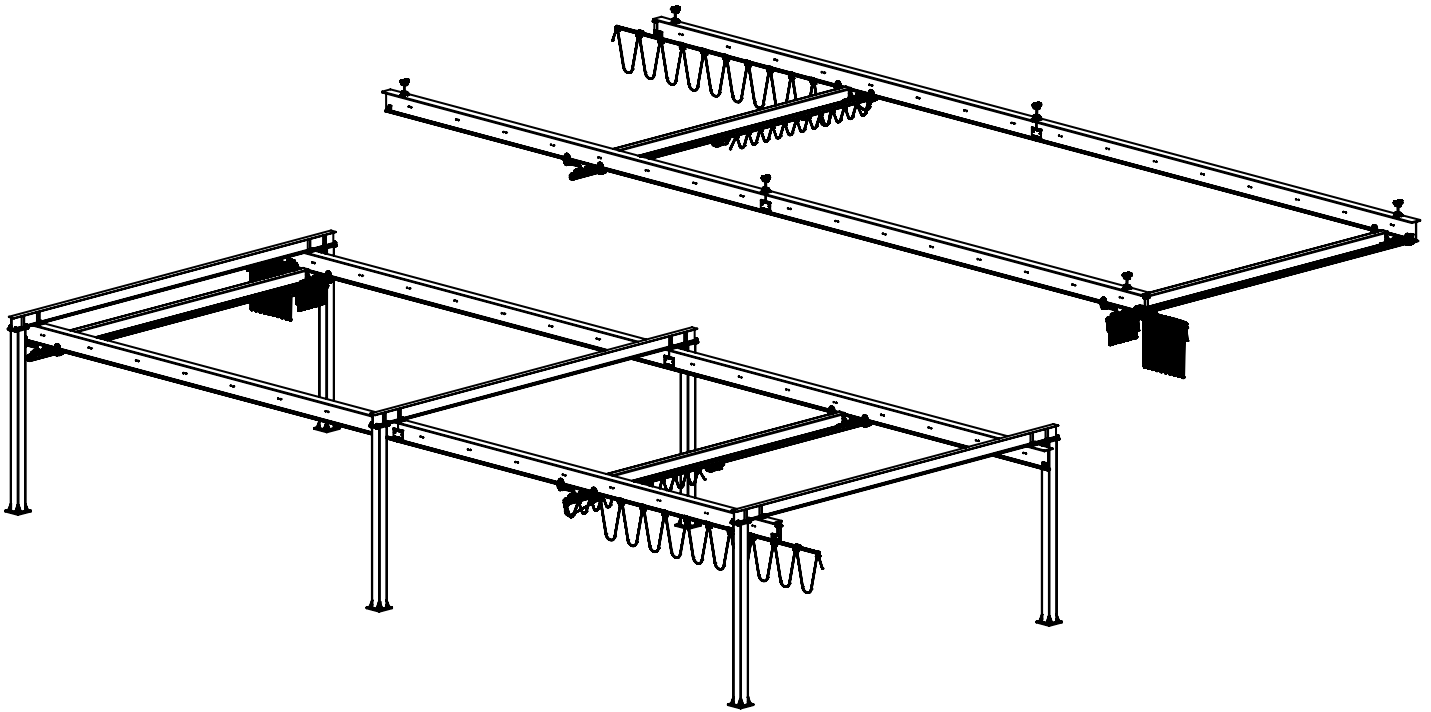

**IMPORTANT!
DO NOT DESTROY**

Hybrid Work Station Crane System

Gorbel® Customer Order No. / Serial No. _____

Gorbel® Dealer _____

Issued: 10/2022

Date _____
Month Year

This page intentionally left blank.

TABLE OF CONTENTS

Introduction..... 1

Installation

- Step 1 - Pre-assembly2-3
- Step 2 - Support Installation4-9
- Step 3 - Runway Installation10-14
- Step 4 - Runway and Bridge End Stop Installation 15
- Step 5 - Bridge and Endtruck Installation16-19
- Step 6 - Hoist Trolley Installation20-21
- Step 7 - Festoon Stack Section Installation22-23
- Step 8 - Festooning Installation24-26
- Step 9 - Bridge Tagline Installation..... 27
- Step 10- Electrobar Elite Conductor Bar (Optional).....28-32
- Step 11- Safe-Lec 2 Conductor Bar Installation (Optional)33-36
- Step 12- Final Steps 37

Sway Brace Guidelines 38-39

Crane Operator / Start Up Instructions 40

General Safety Requirements 40

Limited Warranty 41

Inspection and Maintenance Schedule 42-44

Questions? Concerns? Comments? Please call (800) 821-0086

INTRODUCTION

Thank you for choosing a Gorbel® Hybrid Work Station Crane to solve your material handling needs. The innovative patented track design and heavy-duty construction of the Gorbel® Tarca® Systems combined with the ergonomic features of Gorbel Work Station Cranes will provide a superior quality product that will offer years of long term value. The hoist weight allowance is 15% of the crane's capacity (for example, a crane rated for 4000-pound, allows for a 4000-pound lifted load plus 600 pounds for the weight of the hoist). There is also an allowance of 25% of the crane capacity for impact caused by hoist use. Gorbel® Hybrid Work Station Cranes will provide many years of dependable service by following the installation and maintenance procedures described herein.

Underhung cranes are shipped in various stages of assembly and are installed under varying circumstances. As a result, a complete guide with descriptions covering all variations is not possible. The following instructions are only to be used as a general guide. Attention should be paid to the warnings and safety suggestions posted in this manual and on the equipment.

Dimensions contained in this installation manual are for reference only and may differ for your particular application. Please refer to the enclosed General Arrangement Drawing for actual dimensions.

Normal safety precautions: These include, but are not limited to:

- Checking for obstructions in crane travel
- Checking that all bolts and threaded rods are tight and have lock washers
- Making sure that end stops are in place and functional (i.e. stopping rolling equipment from exiting rail)
- Making sure that festooning cannot be snagged or pinched, whether it is electric or pneumatic
- For additional safety precautions, see page ____.

WARNING

Please read entire manual prior to starting installation.

WARNING

Gorbel Inc. assumes no responsibility for adequacy or integrity of the mounting surfaces or the structure that the crane may be mounted to. Gorbel Inc. will not be liable for any loss, injury or damage to persons or property, nor for damages of any kind, resulting from the failure or defective operation of any materials not supplied directly by Gorbel Inc. Bracing systems, if used, must be approved by a local professional engineer.

WARNING

Before installing any crane system, it is critical you determine that your building will safely support the loads.

WARNING (FREE STANDING)

A minimum of a 6" thick, reinforced concrete floor is required. Support assemblies are designed to AISC (American Institute of Steel Construction) specifications. If no movement of the support assembly is required, additional bracing (not included) to the building steel structure is recommended. See pages ____.

WARNING (CEILING MOUNTED)

Sway bracing (not included) is required for ceiling mounted installations. For additional information, see **Section 13**.

WARNING

Equipment described herein is not designed for, and should not be used for, lifting, supporting or transporting humans. Failure to comply with any one of the limitations noted herein can result in serious bodily injury and/or property damage. Check State and Local regulations for any additional requirements.

WARNING

Crane cannot be utilized as a ground: A separate ground conductor is required. For example, systems with 3 phase power require three conductors plus one ground conductor.

WARNING

Reference the American Institute of Steel Construction (AISC) Manual of Steel Construction Specification for Structural Joints using ASTM A325 or A490 Bolts, Installation, Pretensioned Joints, Calibrated Wrench Pretensioning for the proper procedures to follow when using any torque tightening method.

INSTALLATION

STEP 1 - PRE-ASSEMBLY

- ➡ **TIP:** Packing list can be found in envelope attached to hardware box: General Arrangement Drawing can be found inserted in this installation manual.
- ➡ **TIP:** (FREE STANDING INSTALLATIONS) Recommended guidelines to help you determine anchor bolt size are supplied below (anchor bolts are not included).

- 1.1 Read entire installation manual **before** you begin installing your crane.
- 1.2 Study all instructions and drawings provided in this manual.
- 1.3 Inspect all hole punchings, beam dimensions and suspension fittings or support steel prior to installation.
- 1.4 Check packing list to make sure **correct quantity** of parts is included. Any missing items should be noted and reported to a Gorbel® dealer.
- 1.5 Tools and materials (by others) typically needed to assemble crane are as follows:
 - Mallet
 - Tape measure
 - Hand tools
 - Clamps (large C)
 - Spud wrench
 - Leveling tools (transit, laser level, water level, etc.)
 - Lifting device to lift heavy runways, bridges, headers
 - Welder (if runway splices are welded)
 - For free standing, 3/4" anchor bolts (by others, see 1.6 for length guidelines)
 - Torque wrench
 - Steel shims
 - Ladders/man lifts
 - Large square
 - Shop brush

STEP 1 - PRE-ASSEMBLY - CONT'D

For Free Standing Supports

- 1.6 Recommended guidelines for determining anchor bolt size and type:
- be 3/4" in diameter
 - be grade 5 or better
 - be embedded **at least** 4" into the floor, not to exceed 2/3 of the floor depth (Diagram 1A)
 - have a minimum of two threads above the nut

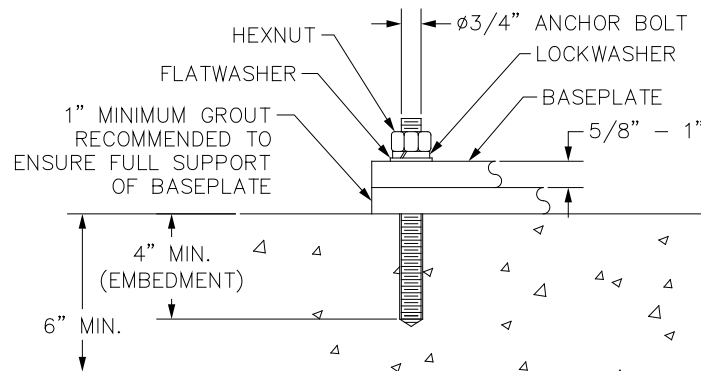

Diagram 1A. Typical anchor bolt embedment.

1.7 Flooring Requirements

- A minimum 6" reinforced concrete floor is required
- Free Standing Hybrid Work Station Crane foundation requirements are based on a minimum soil pressure of 2500# per square foot. Concrete should be a minimum of 3000# per square inch compressive strength. Columns should be centered on a two foot by two foot square area that is free from cracks, seams, and walls.
- Grout is required to ensure the base plates has full contact support to the floor/footing. Shimming/leveling nuts (by others) under the base plate are acceptable methods that would aid leveling of the columns prior to setting the columns on the grout bed. Grout must be a non-shrink, high compressive machinery type grout.
- Chemical (epoxy) anchor bolts are recommended. Chemical anchors to withstand a minimum of 4880# of pull out force

STEP 2 - SUPPORT INSTALLATION

2.1 For free standing supports, go to Step 2.9. For ceiling mounted hangers, continue below.

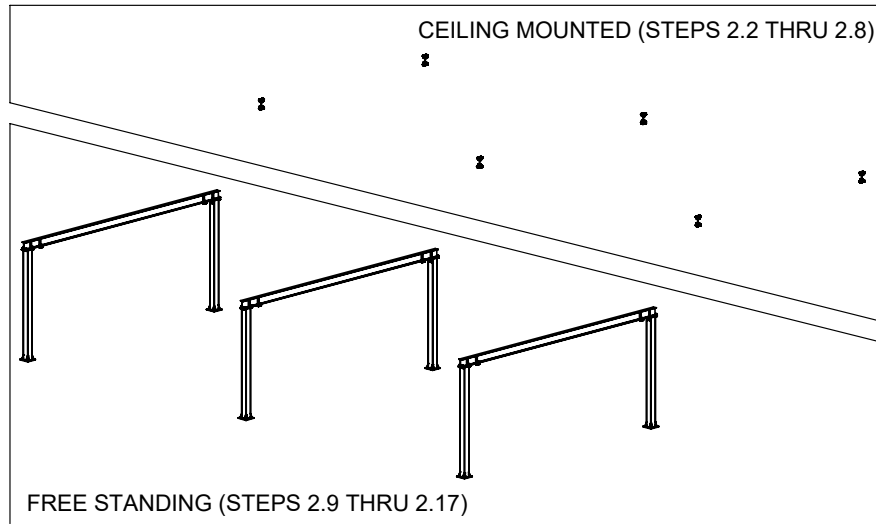

Ceiling Mounted Hanger Installation

2.2 Mark top hanger placement on the building support beams. Runway top flanges are pre-punched with slotted holes for hangers. Verify hanger locations on building support beams match runway slot locations. (refer to the **General Arrangement Drawing**, inserted in this manual, for hanger placement).

STEP 2 - SUPPORT INSTALLATION - CONT'D

- 2.3 Drill holes in superstructure or support. **Diagram 2A** shows the upper hanger hole size and drill pattern for track fitting hanger (dependent on hanger rod diameter).

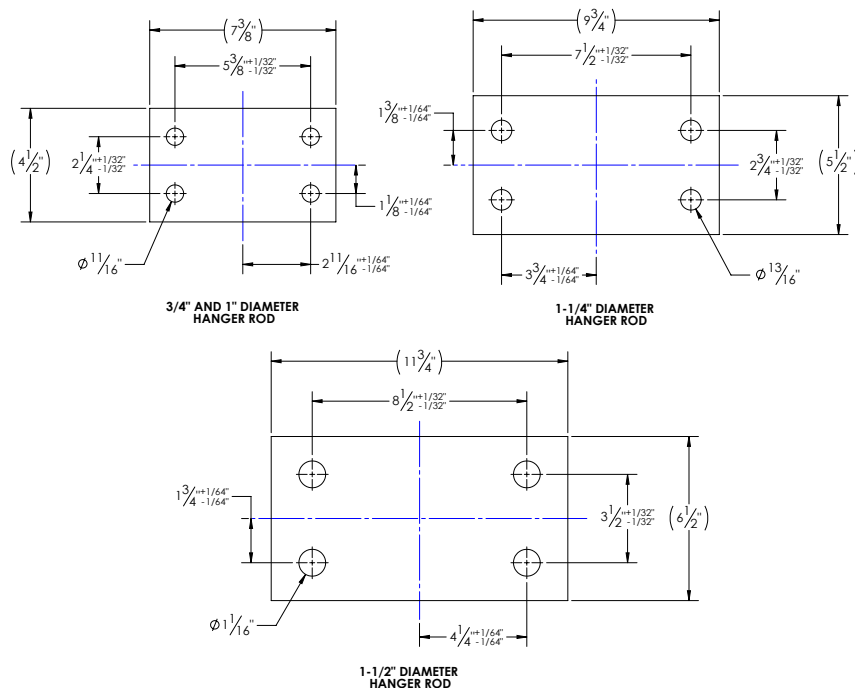

Diagram 2A. Upper Hanger Drill Patterns

- 2.4 Feed threaded rod through upper hanger and thread on load nut. Install roll pin through threaded rod. Lock set screw on load nut before final height adjustment of threaded rod. Attach ceiling fitting (upper hanger assembly) to superstructure or support.
- 2.5 Attach support fitting (lower hanger) to threaded rod and adjust load nut finger tight to threaded rod. Install roll pin through threaded rod.
- 2.6 Set screw in load nut will be tightened after adjusting runway to proper height (Step 3).

WARNING

Threaded rod must have a roll pin installed on both ends.

BOLT OR SCREW SIZE (inches)	SAE GR.2	SAE GR.5 & ASTM A-325	SAE GR.8 & ASTM A-490
1/2	50 lb ft	75 lb ft	110 lb ft
5/8	100 lb ft	150 lb ft	220 lb ft
3/4	125 lb ft	260 lb ft	380 lb ft
7/8	165 lb ft	430 lb ft	600 lb ft
1	250 lb ft	640 lb ft	900 lb ft
1 1/4	500 lb ft	1120 lb ft	1820 lb ft
1 1/2	870 lb ft	1940 lb ft	3160 lb ft
IDENTIFICATION MARKS ON BOLTS HEADS	NO MARK		
TURN OF THE NUT METHOD IS ACCEPTABLE			

Chart 2A. Torque Chart.

STEP 2 - SUPPORT INSTALLATION - CONT'D

2.7 Reference *Diagrams 2B* and *2C* for specific hanger assembly details.

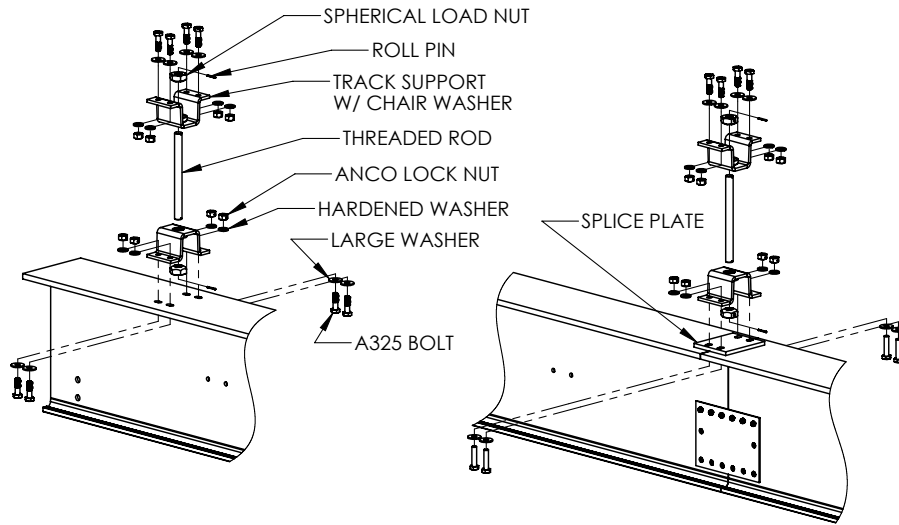

Diagram 2B. *Single Rod Hanger Assembly*
(1" Diameter Rod w/ 5300 Tarca® Track shown)

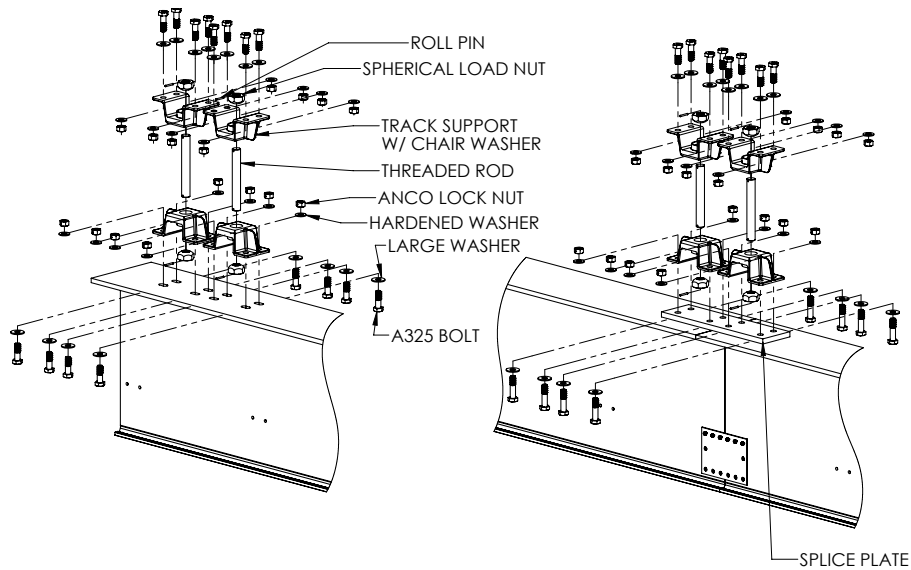

Diagram 2C. *Double Rod Hanger Assembly*
(1-1/2" Diameter Rod w/ 5860 Tarca® Track shown).

2.8 Move to Step 3.

STEP 2 - SUPPORT INSTALLATION - CONT'D

➔ **NOTE:** Be sure that column cap plate (top of column) is oriented in direction of header weldment.
Column gussets must face inward towards bridge and runway as shown.

Free Standing Column Installation

- 2.9** Lay out and mark on floor exact position of column weldments prior to proceeding with installation (refer to enclosed **General Arrangement Drawing** for recommended dimensions and column weldment location).
- 2.10** Position first column weldment in place. Orient column cap plate (top of column) as shown in **Diagram 2D**.

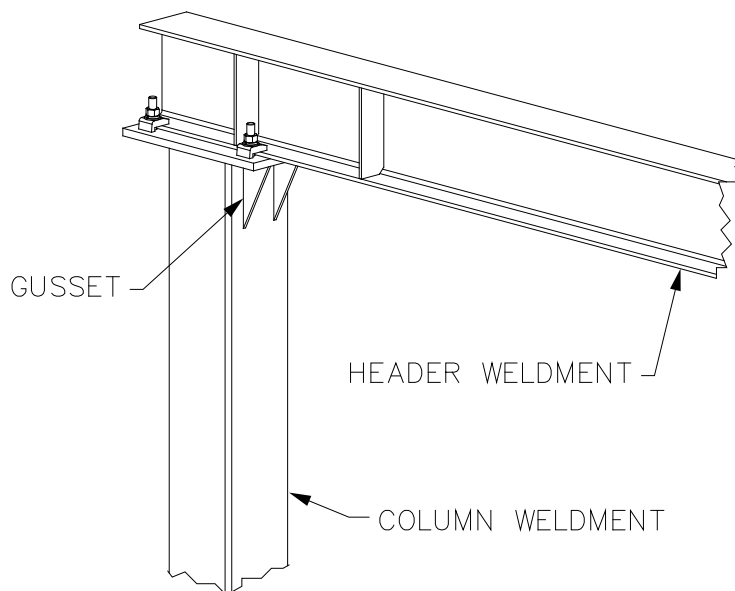

Diagram 2D. Orienting column top plate.

- 2.11** While supporting column weldment, drill holes in concrete floor using pre-drilled holes in column weldment base as a guide (use drill bit size recommended by anchor bolt manufacturer). Vacuum or brush away cement dust.
- 2.12** Install anchor bolts (not included) and hardware according to manufacturer's installation directions and requirements.
- 2.13** Check to see if column weldment is plumb. If column weldment is not plumb, loosen anchor bolt nuts and place steel shims (if required, not included) then grout (not included) under base of column weldment until plumb. After column weldment is plumb, tighten all nuts (**Diagram 1A**, page 2).
- 2.14** Install remaining column weldments (repeat Step 2.10 through 2.13).

STEP 2 - SUPPORT INSTALLATION - CONT'D

Free Standing Header Installation

2.15 Lift and position header weldment onto two secured column weldments (refer to enclosed **General Arrangement Drawing** for recommended dimensions and header weldment location). Using beam clamps (depending on design) and hardware provided, attach header weldment to column weldment.

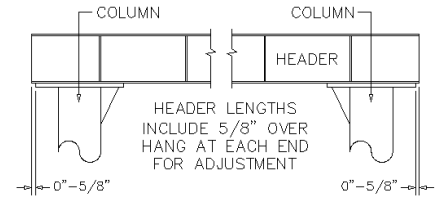

Diagram 2E. Header length.

2.16 For beam clamp connection (**Diagrams 2F & 2G**), tighten hardware. Refer to **Chart 2B** for proper torque.

BEAM CLAMP SIZE	TORQUE	MINIMUM BOLT PRETENSION
5/8"	109 ft.-lbs.	12.3 kips
3/4"	210 ft.-lbs.	19.8 kips
1"	355 ft.-lbs.	25 kips

Chart 2B. Beam Clamp Torque Chart.

WARNING

There must be a minimum of two threads showing at the end of the bolt.

2.17 For direct bolt connection (**Diagram 2H**), tighten hardware. Refer to **Chart 2A** for proper torque.

➔ **NOTE:** For simplicity of installation, hardware provided will be equal size and length for both runway and column connections. If required, use a second hardened washer at column connection to prevent bottoming out nut on threads.

STEP 2 - SUPPORT INSTALLATION - CONT'D

2.18 Install remaining header weldments (repeat Steps 2.15 through 2.16).

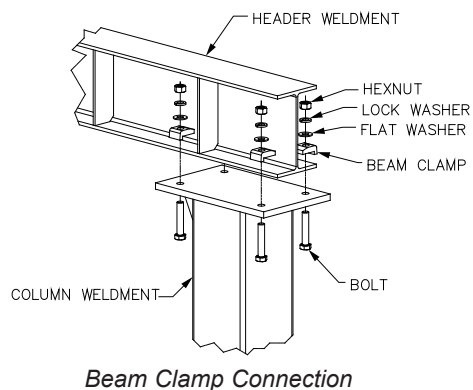

Diagram 2F. Installing header weldments.

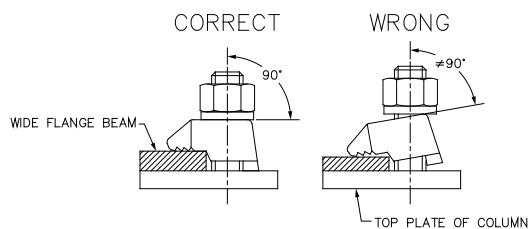

Diagram 2G. Beam Clamp Installation.

➡ **NOTE:** 10" tall, wide flange headers with 5/8" hardware require a shim (supplied) to obtain the correct beam clamp tail length to match the header flange thickness.

WARNING

If shimming column, shim must be located between floor and baseplate. Shims must not be located at top of column.

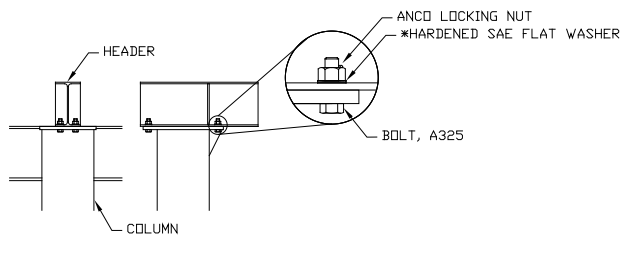
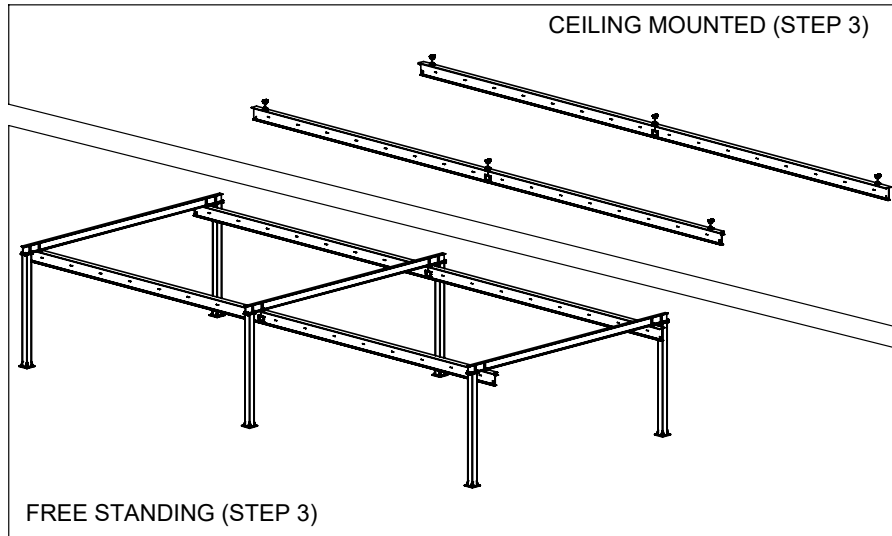

Diagram 2H. Column to Header Connection

STEP 3 - RUNWAY INSTALLATION



3.1 Suspend runway section under installed support structure (refer to enclosed **General Arrangement Drawing** for recommended support points, dimensions and runway location).

➡ **NOTE:** When using runway festooning, a runway will have an angle welded at one end to install the stack section, orient this as required. Also, the endstop holes will be located in the web at the stack section end. The second runway must be oriented with the web mounted endstop at the same end as the runway with the stack section to ensure equal impact with the bridge endtrucks.

3.2 Check to make sure that runway is level (within +/- 1/4") and parallel to opposite runway (within +/- 3/16") over any span.

WARNING

Do not deviate from the bridge "span" dimension shown on the General Arrangement drawing. Bridge "span" is the distance (+/- 3/16") between runways (centerline to centerline).

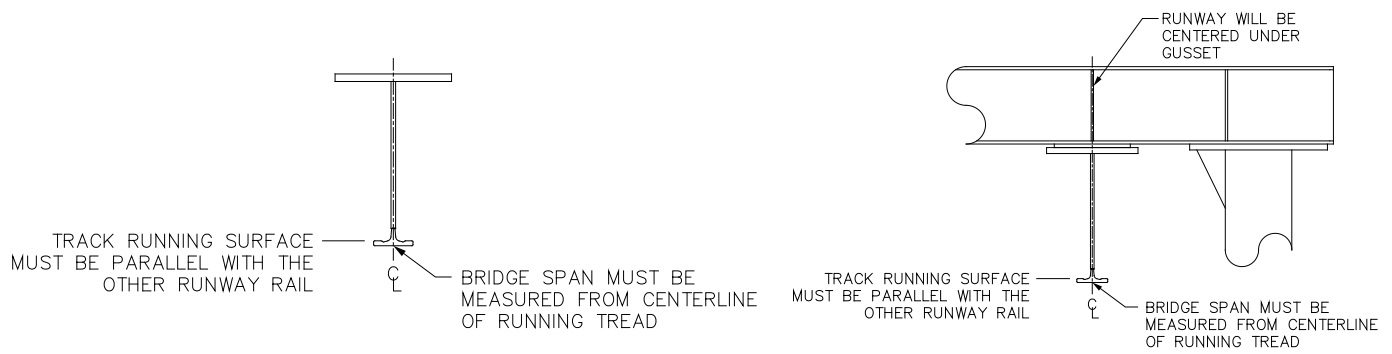

Diagram 3A. Track Perpendicularity.

STEP 3 - RUNWAY INSTALLATION - CONT'D

3.3 For Ceiling Mounted systems, skip to Step 3.7.

➡ **NOTE:** Runway to be centered under gussets.

3.4 Using beam clamps (depending on design) and hardware provided, attach runway section to header weldment, as shown in **Diagram 3B**.

WARNING

If shimming runway, shim must be located between washer plate and top of runway.

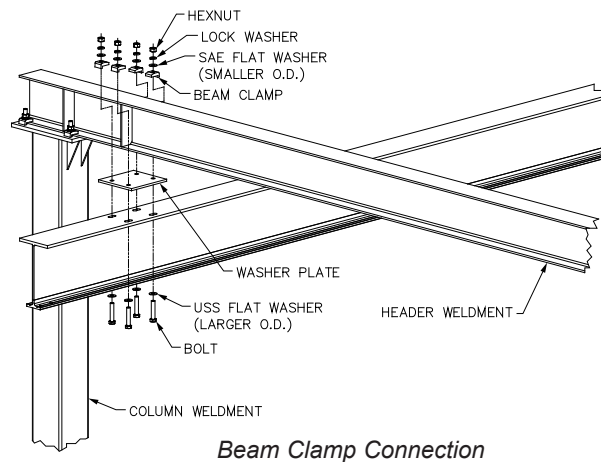

Diagram 3B. Attaching runway to header weldment.

3.5 For beam clamp connection, tighten hardware (**Chart 2B**, page 8), for proper torque rating.

WARNING

There must be a minimum of two threads showing at the end of the bolt.

3.6 For direct bolt connection (**Diagram 3C**), tighten hardware. (**Chart 2A**, page 5, for proper torque rating)

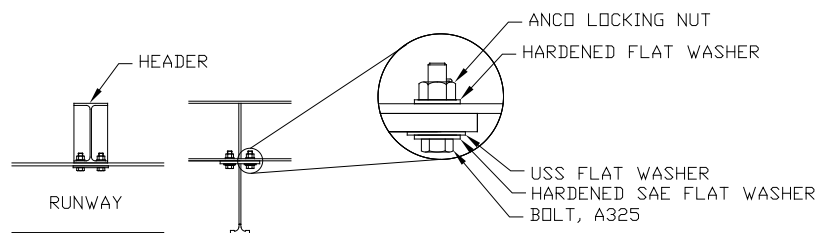

Diagram 3C. Runway Direct Bolt Connection

STEP 3 - RUNWAY INSTALLATION - CONT'D

- 3.7 If you **DO NOT** have additional runways to install, proceed to Step 4, on page 15; otherwise proceed to Step 3.9.
- 3.8 For ceiling mounted runways attaching to hangers, tighten hardware (**Chart 2A**, page 5, for proper torque rating).

WARNING

There must be a minimum of two threads showing at the end of the bolt.

- 3.9 If you **DO NOT** have additional runways to install, proceed to Step 4, on page 15; otherwise proceed to Step 3.10.

Splice Joint Installation

WARNING

Reference the General Arrangement Drawing for splice locations. It will be necessary to install adjacent runways at the same time.

- 3.10 Bring the ends of the track sections together as close as possible (**Diagram 3D**).

WARNING

If shimming runway, shim must be located between washer plate and top of runway.

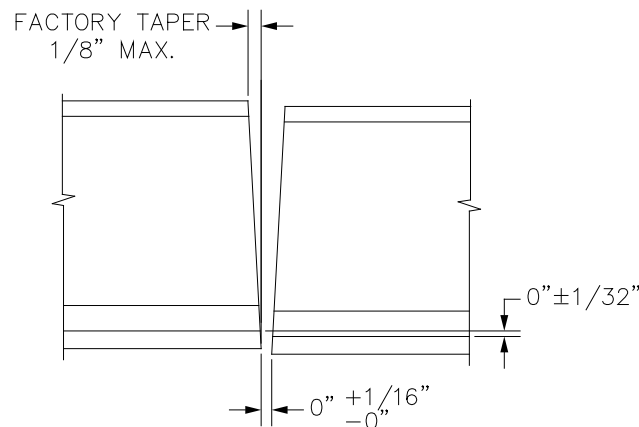

Diagram 3D. Rail Alignment.

STEP 3 - RUNWAY INSTALLATION - CONT'D

- 3.11** Align holes in washer plate or splice plate with the slots in the top flange of the rail. Tighten hanger or direct bolt hardware (**Chart 2A**, page 5 for proper torque rating) or beam clamp hardware (**Chart 2B**, page 8 for proper torque rating). This will help align the top flange portion of track sections.
(**Diagram 2B** for single hangers, or **Diagram 2C** for double hangers, or **Diagram 3E** for headers.)

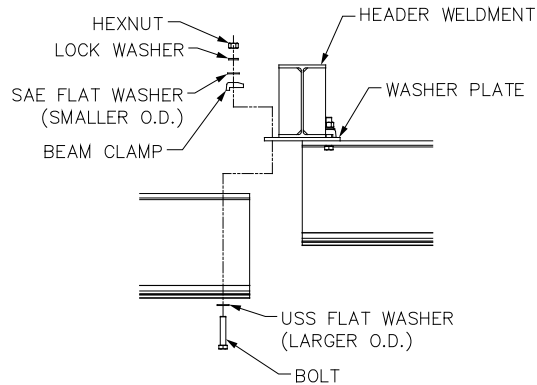

Diagram 3E. Attaching header to top flange.

- 3.12** Place web splice plate(s) on each side of web section. Align plate as shown (**Diagrams 3F** and **3G** for welded splice or **Diagrams 3J** and **3K** for bolted splice).

WARNING

Track sections and web plate need to be carefully aligned before field welding of plates to allow smooth transition between sections.

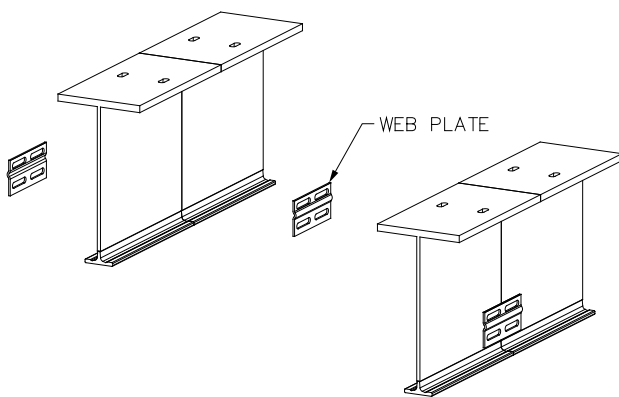

Diagram 3F. Welded splice (4200-4600 Tarca® beam).

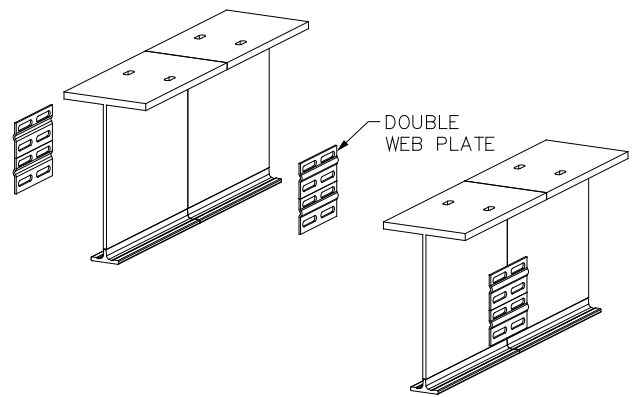

Diagram 3G. Welded splice (5000 & Larger Tarca® beam).

- 3.12** Web splice plates to be welded in accordance with American Welding Society (AWS) specification D1.1 using E70xx electrodes (**Diagram 3H**).

WARNING

If welding of lower track is desired (not required), different electrodes are required for mild steel vs. hardened steel. E7018 is used for mild steel only (web and top flange). E11018 must be used for hard steel and may also be used for mild steel.

STEP 3 - RUNWAY INSTALLATION - CONT'D

- 3.14 Check to see that the transition from one track to the other is smooth: no raised areas to inhibit carrier or end truck operation (**Diagram 3D**).
- 3.15 For additional runways repeat Steps 3.9 through 3.13.

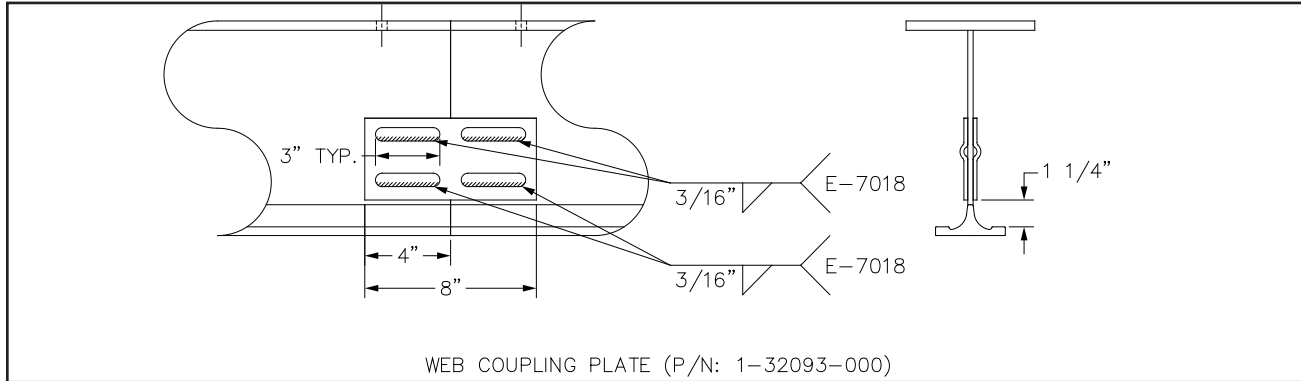

Diagram 3H. Splicing Runways together.

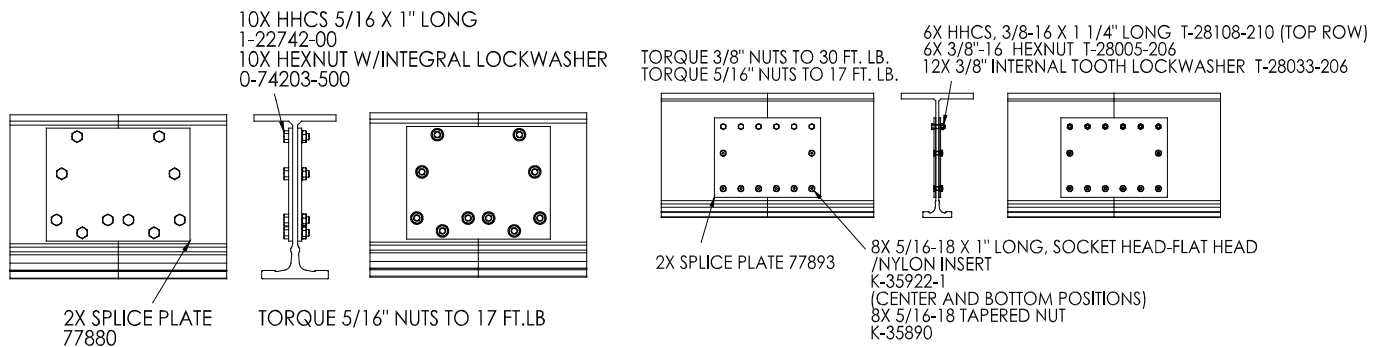

Diagram 3J. Bolted splice (4200 - 4600 Tarca® beam).

Diagram 3K. Bolted splice (5000 and larger Tarca® beam).

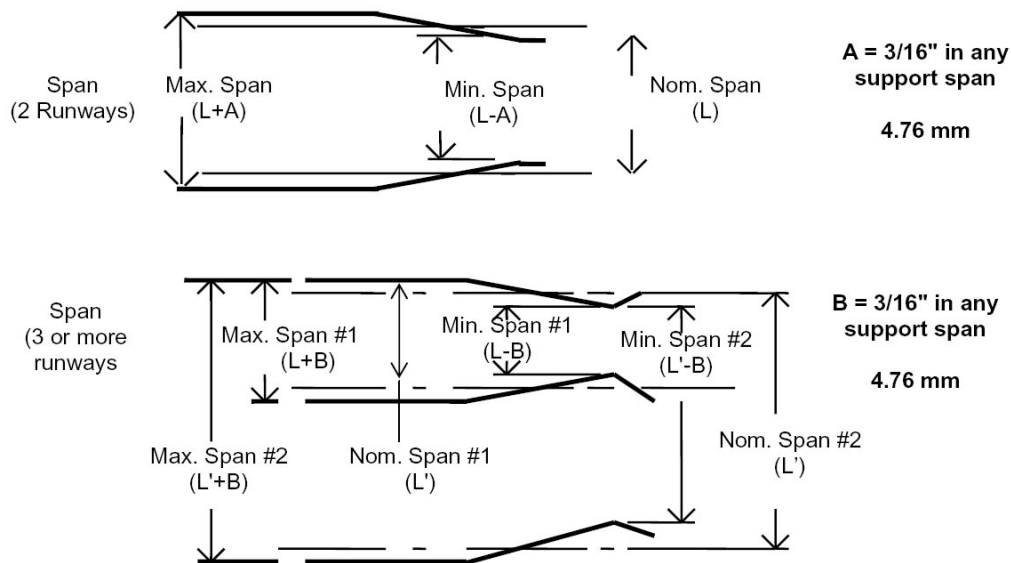

Diagram 3L. Runway alignment tolerance.

STEP 4 - RUNWAY AND BRIDGE ENDSTOP INSTALLATION

- 4.1 End stops are required and must be installed at the ends of the crane travel on runways and at the ends of the trolley travel on bridge(s). Leave one end open for bridge and endtruck installation (Step 5) or for trolley and hoist installation (Step 6) and then immediately install once bridge(s) or trolley is in place. Torque hardware per **Chart 2A**, page 5.

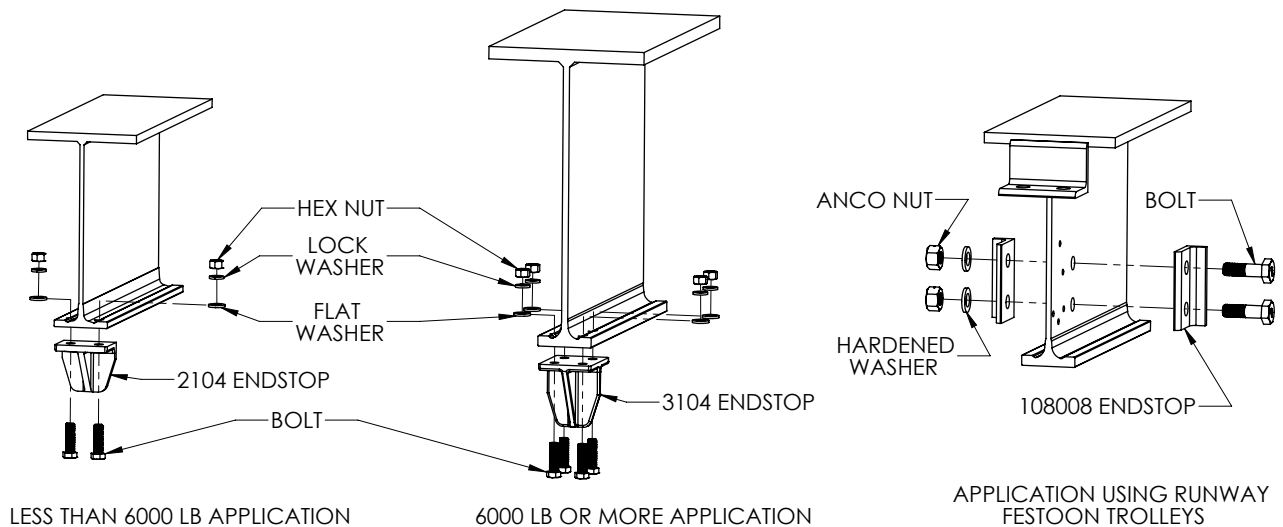

Diagram 4A. Standard Runway Endstops.

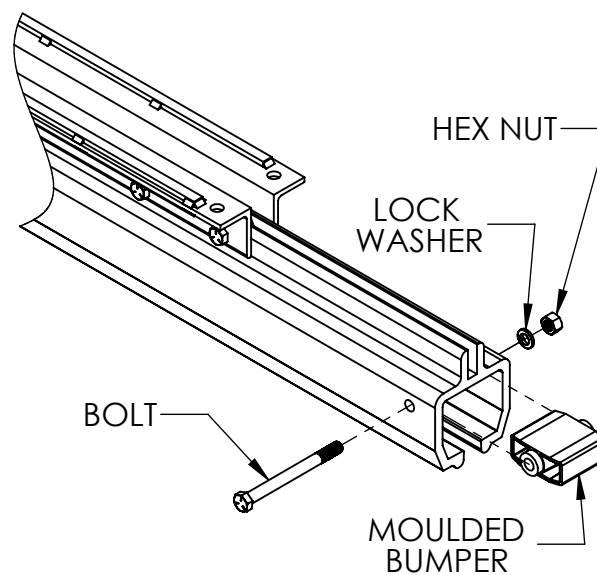
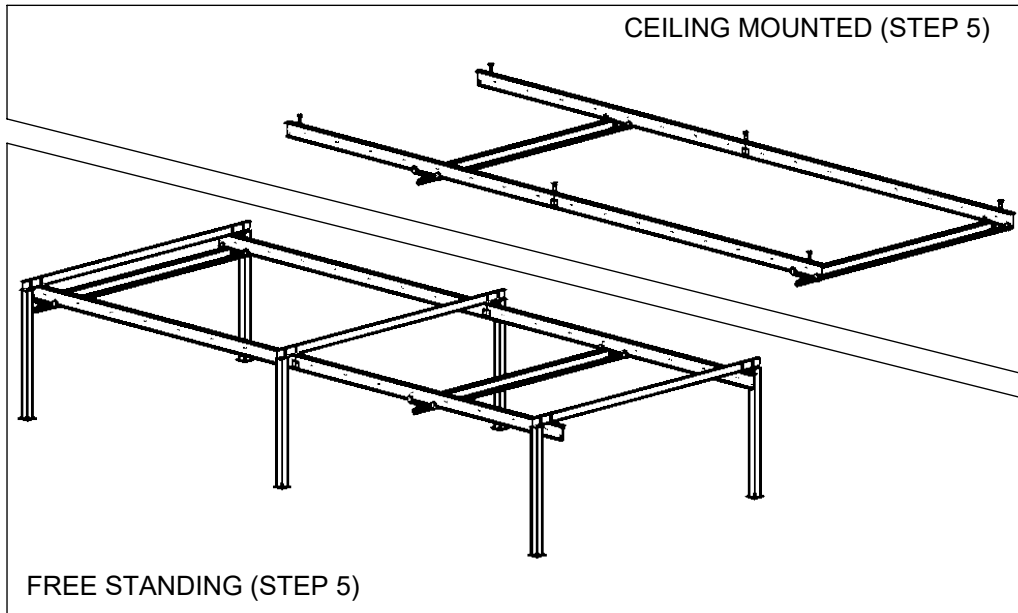

Diagram 4B. Bridge Endstop.

- 4.2 The standard runway endstops are for normal applications where contacts with endstops are infrequent and travel is at slow speed.
- 4.3 When service conditions are such that the carrier, trolley, or crane will contact the endstop frequently or at high speed, spring bumpers or other energy absorbing type endstops are available and should be used. For their application and detail contact our Inside Sales Department.

STEP 5 - BRIDGE AND ENDTRUCK INSTALLATION



- 5.1 Make sure end stops have been installed in the runway end opposite the festooning (leaving festooning end open for bridge installation).
- 5.2 Prior to adding bridge, clean inside flanges of track and rail tread with clean, dry cloth (**do not use any kind of cleaning solution**) to remove grit or debris that may have collected during shipping, storage, or installation.
- 5.3 Hybrid endtrucks are shipped unassembled. They vary depending on application. See **Chart 5A**.

HYBRID END TRUCKS

					
ITEM NUMBER	A1062	A1065	A2062	A4062	A4065
OVERALL LENGTH (IN)	30.5	42.5	31.5	31.5	51.5
WHEELBASE (IN)	24	36	24	24.0	44.0
AL BRIDGE SERIES	250 - 1000	250 - 1000	2000	4000	2000 - 4000
BRIDGE LENGTH (FT)	4 TO 23	>23 TO 34	4 TO 23	4 TO 23	>23 TO 34

Chart 5A. Hybrid Endtruck Properties.

➔ **NOTE:** Endtruck should be assembled before attaching to bridge.

If using Safe-Lec conductor bar (**Step 11**), tow-arm bracket must be installed when assembling endtruck. See **Diagram 11G**.

STEP 5 - BRIDGE AND END TRUCK INSTALLATION - CONT'D

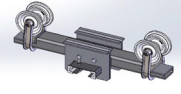
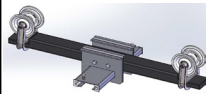
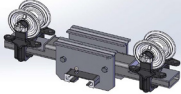
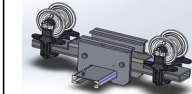
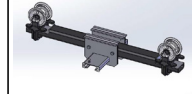
- 5.4 Slide tube weldment halfway through support weldment. Insert a support bolt in each hole of the support weldment, passing through tube weldment (**Diagram 5A**).

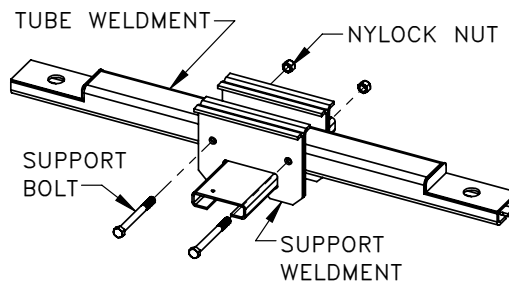

Diagram 5A. Assembling Endtruck.

- 5.5 Place nylock nut on end of each bolt and tighten snug against endtruck support weldment.

WARNING

Do not “over-tighten” nylock nut. This could cause damage to endtrucks. Nylock nut can only be used once. If this item is disassembled, then nut must be replaced.

- 5.6 For 2000 pound and 4000 pound endtrucks, slide tube weldment through idler head and align holes. Position thrust washer between idler head and underside of tube weldment and align holes. Insert trunnion pin and capture with retaining ring. Similarly assemble other idler head (**Diagram 5B**).

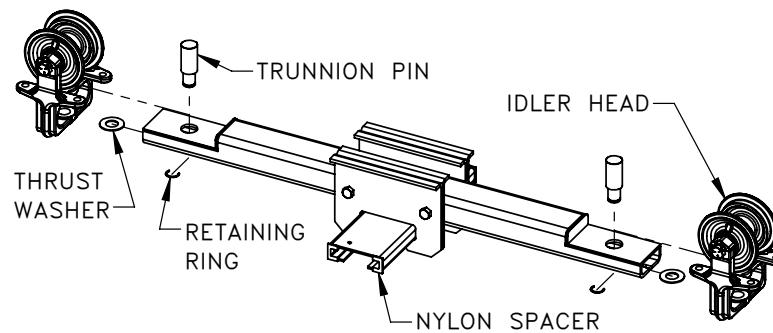

Diagram 5B. Installing idler heads on greater than 1000 pound capacity bridges.

- 5.7 For 1000 pound endtrucks, slide tube weldment through idler head and align holes. Insert trunnion pin and capture with cotter pin. Similarly assemble other idler head (**Diagram 5C**).

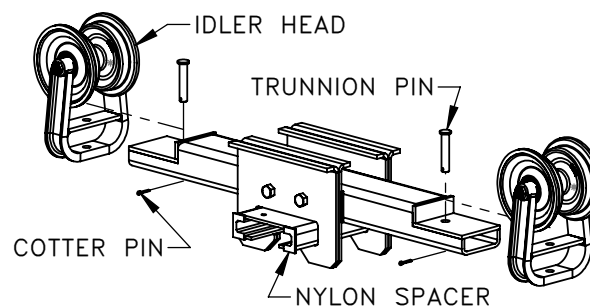

Diagram 5C. Installing idler heads on 1000 pound or less capacity bridges.

STEP 5 - BRIDGE AND END TRUCK INSTALLATION - CONT'D

- 5.8 Make sure nylon spacers are attached to endtruck before installing endtruck on bridge.
- 5.9 Slide an end truck over steel brackets on the festooning end of bridge (refer to the **General Arrangement Drawing** for exact endtruck location) and clamp into place (**Diagram 5D**).

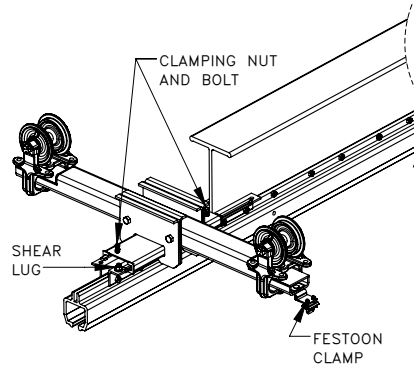

Diagram 5D. Installing clamping endtruck on two piece aluminum bridge. (See NOTE)

➡ **NOTE:** The festooning end of the bridge will have an endstop hole that is inset the same or greater distance from the end of the bridge than the endstop hole in the opposite end of the bridge.

- 5.10 Slide and position the non-clamping end truck on the other end of bridge (refer to the **General Arrangement Drawing** for exact location).

➡ **NOTE:** ONLY ONE endtruck is clamped to the bridge, the other endtruck is not. The clamping end truck must be oriented with the festooning or conductor bar side of the runway. The non-clamping endtruck allows adjustment for any runway misalignment and bridge deflection.

- 5.11 At both ends of bridge, install a shear lug bolt in hole at end of steel brackets to prevent bridge from sliding out of endtrucks (**Diagram 5D**).

➡ **NOTE:** Install bolts with head of bolt on underside of top flange with the threads pointing up.

WARNING

Failure to install shear lug bolt assemblies may result in the bridge, hoist, and load falling to the floor.

- 5.12 If runway festooning is being utilized, install a festoon clamp in the slot on the endtruck tube weldment on the side toward the festoon stack section (**Diagram 5D**).

➡ **NOTE:** This festoon clamp will act as a tow arm to ensure the runway festoon trolleys are being pulled at the center-line of the runway track.

STEP 5 - BRIDGE AND END TRUCK INSTALLATION - CONT'D

- 5.13 Install an endstop to the end of the bridge opposite the festooning (*Diagram 4B*)
- 5.14 Lift bridge up to runways and simultaneously insert endtrucks into open ends of runways. Make sure festooning end of bridge is oriented with festooning or conductor bar runway.
- 5.15 Immediately install endstops in open ends of runways to prevent bridge from exiting runways (*Diagram 4A*).
- 5.16 Roll bridge down length of runways to check for smooth travel. If travel is not smooth, check track for level and parallel (*Diagram 3K*) and check to make sure that only one end truck on the bridge is clamped.

STEP 6 - HOIST TROLLEY INSTALLATION

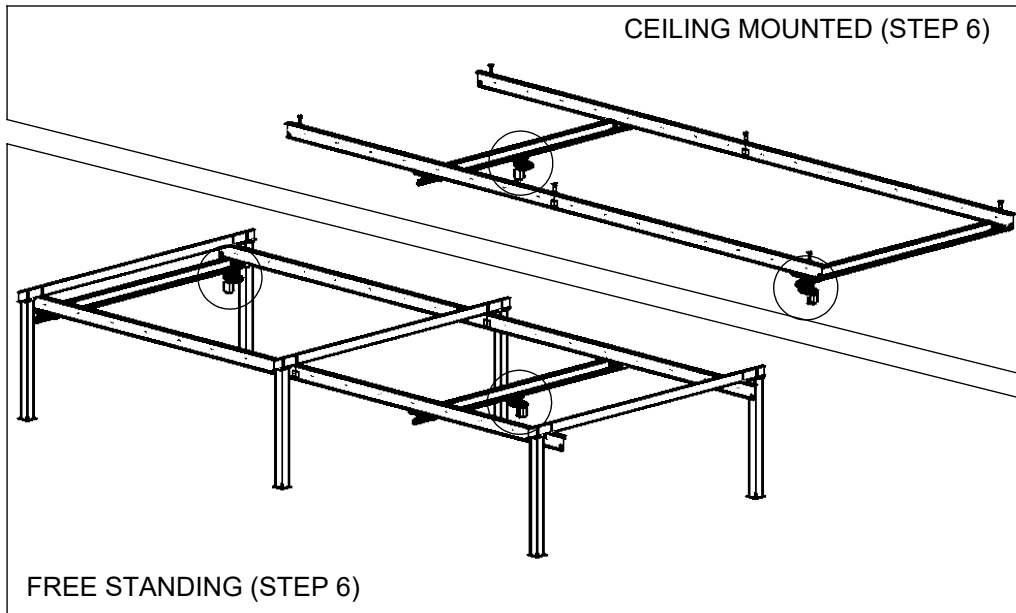

6.1 Locate hoist trolley(s) (*Diagram 6A*).

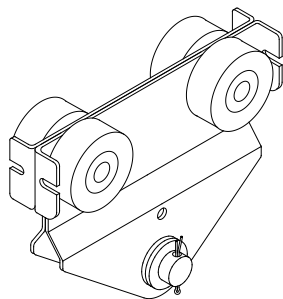

Shipped Assembled.
Capacity = 2000 pounds
and under

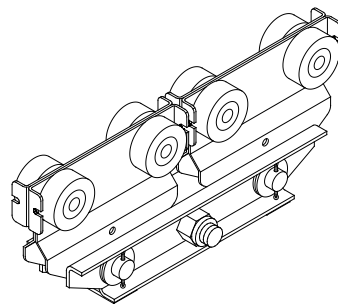

Shipped Assembled.
Capacity = 4000 pounds

Diagram 6A. Hoist Trolleys

- 6.2 Clean inside flanges of track with a clean, dry cloth (do **NOT** use any kind of cleaning solution) to remove grit and/or debris that may have collected during shipping, storage, or installation.
- 6.3 Ensure endstop is installed opposite the festooning end of the bridge.
- 6.4 If using a hoist with a suspension hook, attach hoist by snapping hoist suspension hook over the trolley saddle clevis pin/bolt.

WARNING

On 4000# hoist trolley, hang hoist from clevis bolt (center bolt) only.

STEP 6 - HOIST TROLLEY INSTALLATION - CONT'D

- 6.5** If installing a Gorbel® GS Hoist, or the hoist has a suspension device other than a hook, remove trolley saddle clevis pin/bolt and install suspension plate. For 2000 pound or less trolleys, insert clevis pin and a washer back into place. Slide remaining washers on clevis pin and insert cotter pin through trolley saddle clevis pin (**Diagram 6B**). Bend back both legs of cotter pin (**Diagram 6D**). For 4000 pound trolleys, insert clevis bolt and secure with nylock nut. Tighten until snug (**Diagram 6C**).

WARNING

Fully bend both legs of cotter pin (**Diagram 6D**). If cotter pin is cracked or fatigued, it must be replaced.

WARNING

For 4000# trolley, be sure to tighten nut on the clevis bolt (center bolt) of hoist trolley. Over tightening nylock nut could cause damage to the trolley. Nylock nut on clevis bolt should only be used once. If this item is disassembled, the nylock nut must be replaced.

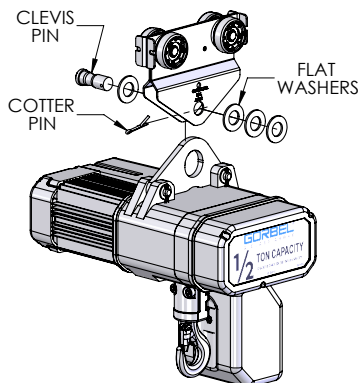

Diagram 6B. Installing hoist on 2000# or less hoist trolley

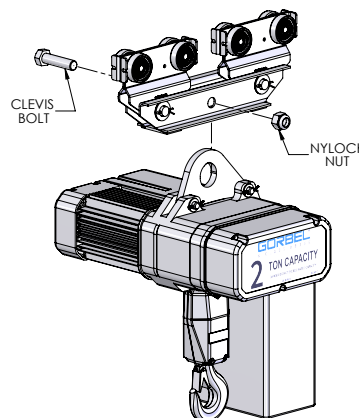

Diagram 6C. Installing hoist on 4000# hoist trolley

- 6.6** Roll hoist trolley into open end of track on bridge/monorail.
- 6.7** Install end stop on the festooning end of bridge/monorail (**Diagram 4A**, on page 16).
- 6.8** If you have tagline, go to Step 9.

If you **do not** have festooning, go to Step 11.

If you **do not** have a festoon stack section, go to Step 8.

Otherwise go to Step 7.

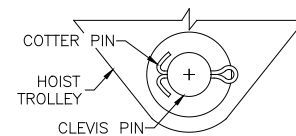
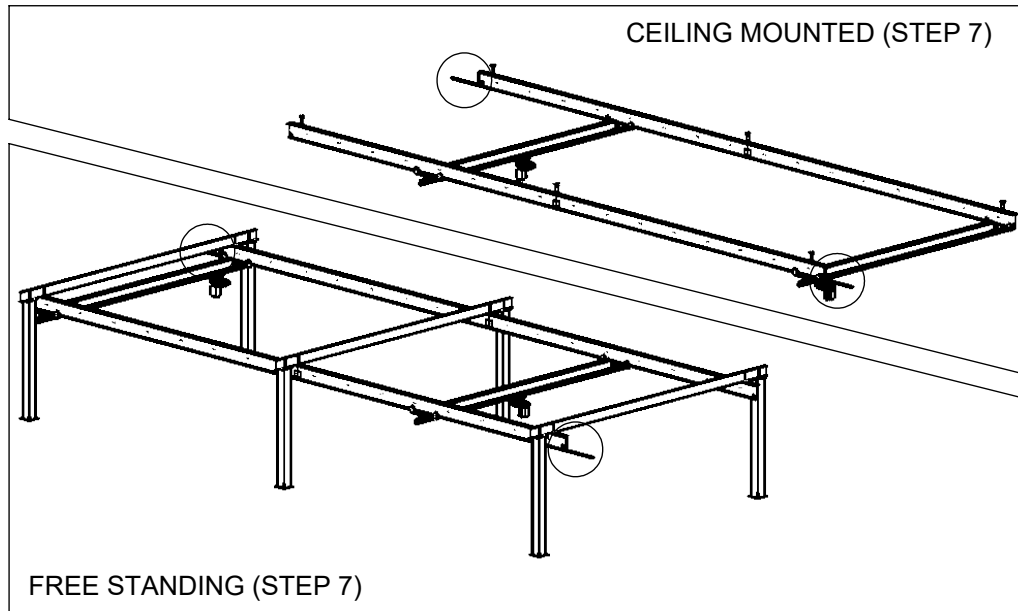

Diagram 6D. Installing cotter pin through trolley saddle clevis pin.

STEP 7 - FESTOON STACK SECTION INSTALLATION



➡ **TIP:** Festoon stack section allows festooning to stack up at the end of they system, permitting full use of runway.

7.1 Prepare trolleys. Loosen eight screws, center wheel plates on aluminum extrusion to 3.75 - 3.69 wheel spacing shown (**Diagram 7A**) and tighten screws.

➡ **NOTE:** For all systems with runway festoon trolleys: Each festooned runway wire can only supply power to one bridge. For a two bridge system, two sets of festooning is required, one on each end of the runway(s). For more than 2 bridges conductor bar is recommended.

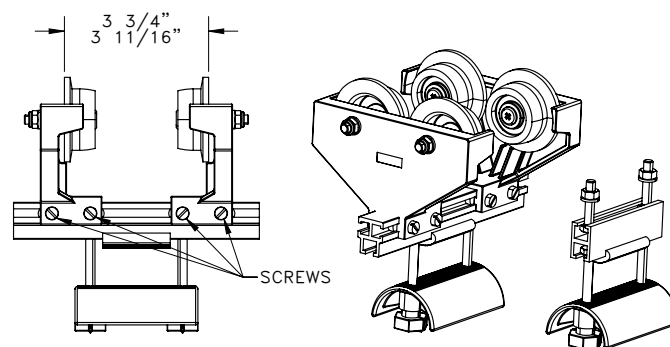

Diagram 7A. Runway Festoon Trolley & Runway Festoon Clamp (Flat cable trolley shown)

STEP 7 - FESTOON STACK SECTION INSTALLATION

7.2 Festoon stack weldment will vary in length depending on runway length and festoon loop height.

➔ **NOTE:** 3' festoon loop heights are typical for runways and 1-1/2' loop heights are typical for bridges. The runway that has been prepared to accept the stack section will have an angle welded on the end and will have pre-drilled holes for the splice plates.

7.3 Carefully support and raise the stack section into place and secure with 3/4" hardware. (**Diagram 7B**).

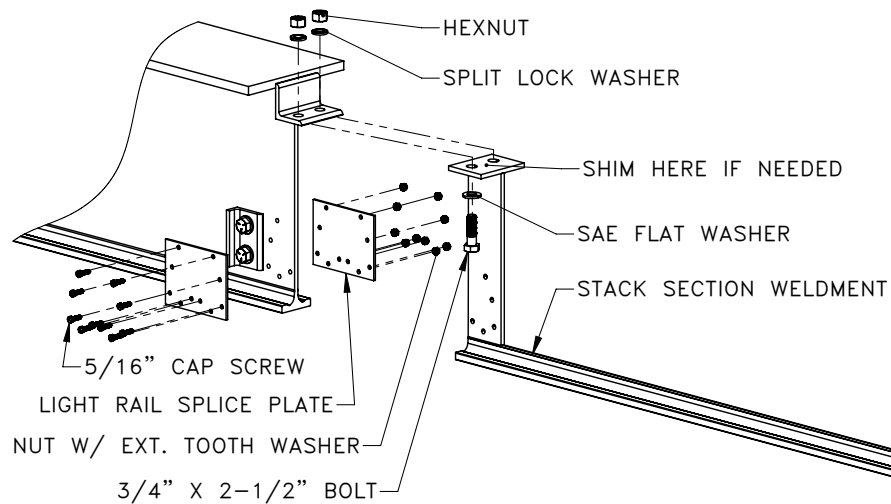

7.4 Snug hardware and verify track wheel surfaces are aligned. If necessary, add a shim between the runway angle and the stack section top plate.

7.5 Once aligned, install splice plates and 5/16" hardware. Tighten all hardware.

STEP 8 - FESTOONING INSTALLATION

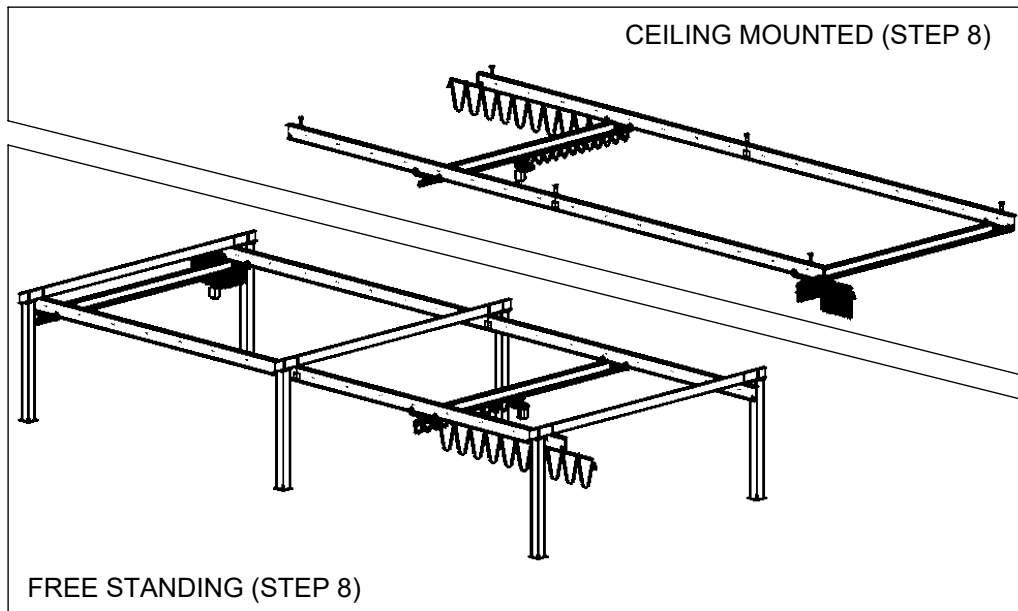

- 8.1 Roll bridge festoon trolleys through open end of bridge that corresponds with festooning on runway. Space festoon trolleys every 3'-0" along bridge.

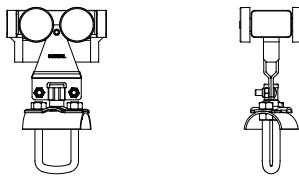

Diagram 8A. Bridge Festoon Trolley

- 8.2 Slide festoon clamps into place at festooning end of bridge and endtruck. Tighten carriage bolt (**Diagram 8B**).

➔ **NOTE:** Festoon clamp on endtruck allows for runway festoon trolleys to be pulled along center of runway.

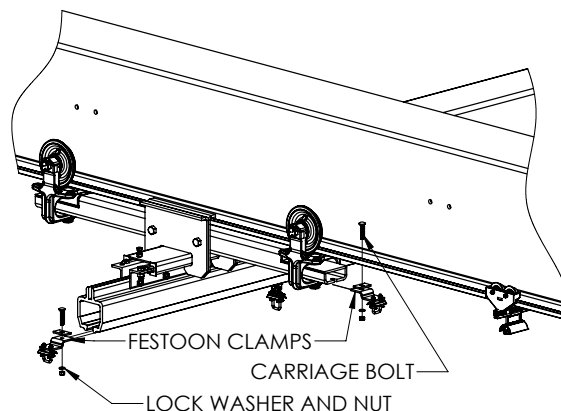

Diagram 8B. Festoon Clamp Installation - Bridge and Endtruck

STEP 8 - FESTOONING INSTALLATION

- 8.3 Roll runway festoon trolleys down festoon stack welment. Verify endtruck does not collide with trolleys when the endtruck is up against the endstop. (**Diagram 8C**). Install runway festoon clamp at the end of festoon stack and tighten mounting bolts.

➔ **NOTE:** If endtruck interferes with stacked festoon trolleys, remove festoon trolleys as needed to allow clearance.

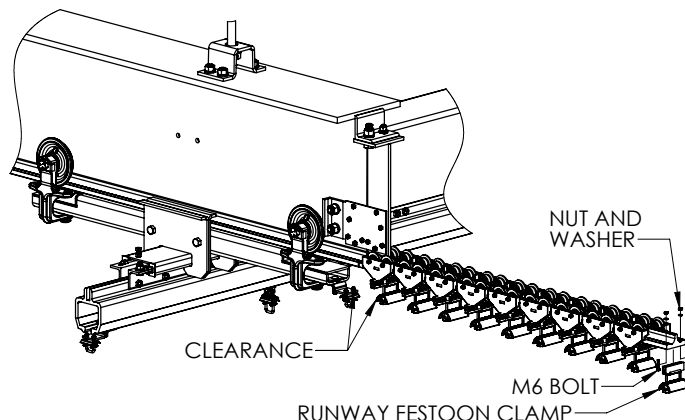

Diagram 8C. Runway festoon clamp on installation on stack section.

- 8.4 Evenly space festoon trolleys along runway. For 3' festoon loop height, trolleys should be spaced every 6'. Loop height may vary, up to 6', depending on system configuration at order.

8.5 Installing Festooned Electric Cable/Air Hose:

Festoon trolleys are designed to accept 4-conductor, electric flat or round cable (#12 or #14 gauge) or air hose (maximum: 7/8" outside diameter).

Loosen nuts and clamp-plate enough to thread electric cable/air hose between the bolt legs and clamp plate on festoon trolley. Secure cable by tightening nuts on festoon trolley, forcing clamp plate snug against electric cable/air hose (**Diagram 8D**).

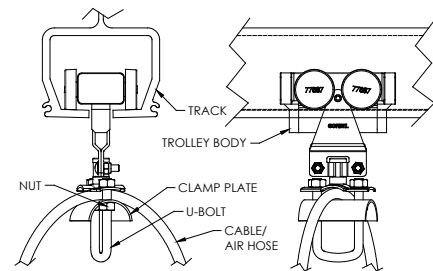

Diagram 8D. Installing electric cable or air hose on festoon trolley.

➔ **NOTE:** Be careful not to tighten nuts too tight. This will cause damage to electric cable/air hose.

➔ **NOTE:** Standard runway festoon trolleys are for flat cable. If round cable or air hose trolleys are required, contact Customer Service.

➔ **NOTE:** On bridge festoon trolleys, be sure that U-bolt does not interfere with trolley body.

➔ **IMPORTANT:** Cable/Air Hose Installation: It is important that as much twist as possible be taken out of the hose before it is hung.
To take the twist out follow the steps below:

1. Lay the cable or hose out on the floor flat.
2. Mark the cable or hose where the first end clamp will be and then make marks for runway trolley, endtruck and bridge end clamp, and bridge trolley locations. Allow 10% longer spacing than trolley spacing for cable/hose sag. If cable or hose twist still exists, increase intervals.
3. Recoil the cable or hose so that the marks are all lined up on the top of the coiled cable or hose.
4. Lay the large coil on the floor with the marks lined up. At each mark, attach a trolley or end clamp. When installing the festoon, pick up the whole coil and run the trolleys in without disturbing the coil.

Suggestion: Air Swivels should be used at either end of cable or hose to reduce twist.

STEP 9 - BRIDGE TAGLINE INSTALLATION

9.1 Attach tagline brackets and backing angles to aluminum bridge web (*Diagram 9A*).

Note: Do not forget to install the backing angle on the web opposite to the tagline angle.

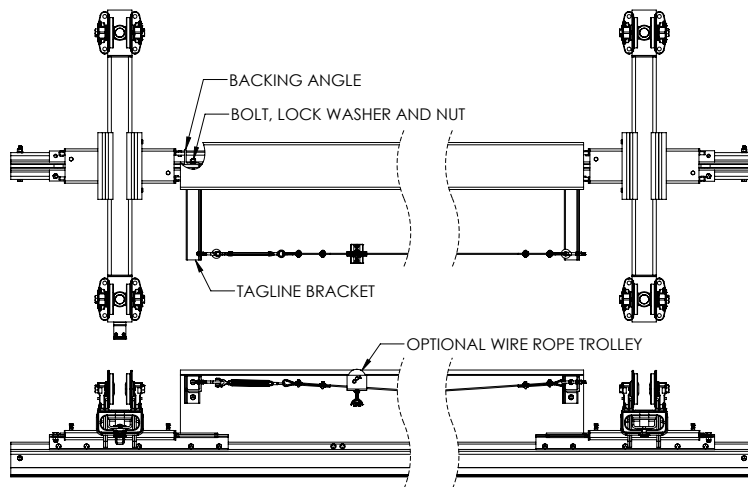

Diagram 9A. Tagline on coped aluminum bridge.

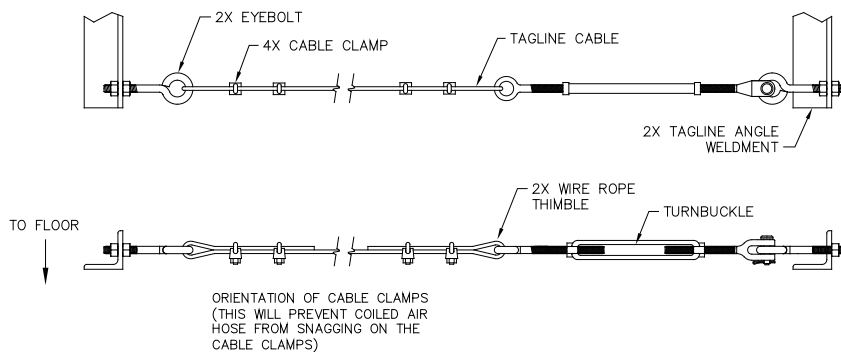

Diagram 9B. Tagline cable assembly.

9.2 Attach eyebolts onto tagline brackets. Attach turnbuckle to one eyebolt. Loop cable through eyebolt or turnbuckle and turn back 4-3/4" of cable on a thimble. Apply first clamp 1" from the dead end of the cable and tighten U-bolt to 15 ft.-lbs. or torque. Apply the second clamp as close to thimble as possible. Tighten U-bolt to 15 ft.-lbs. of torque (*Diagram 9C*).

9.3 Add any S-hooks, wire rope trolleys, or coiled air hose to the cable prior to attaching the other end.

9.4 Secure other end of the cable as in Step 9.2.

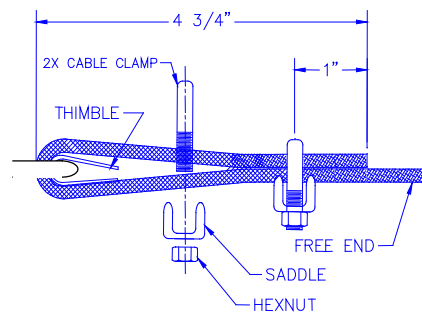

Diagram 9C. Saddling the cable on one end.

STEP 10 - ELECTROBAR ELITE CONDUCTOR BAR (OPTIONAL)

Runway Conductor Bar Installation

10.1 Establish the orientation of the collector tow arm. For endtrucks with short bridge sleeves (2000# or less bridge capacity and 23' or less bridge length). The collector tow arm must be mounted facing outward (**Diagram 10A**). The innermost hole of the hanger bracket will be used to mount the hangers. For endtrucks with long bridge sleeves (4000# capacity or bridges over 23'), the collector tow arm may be oriented inward or outward.

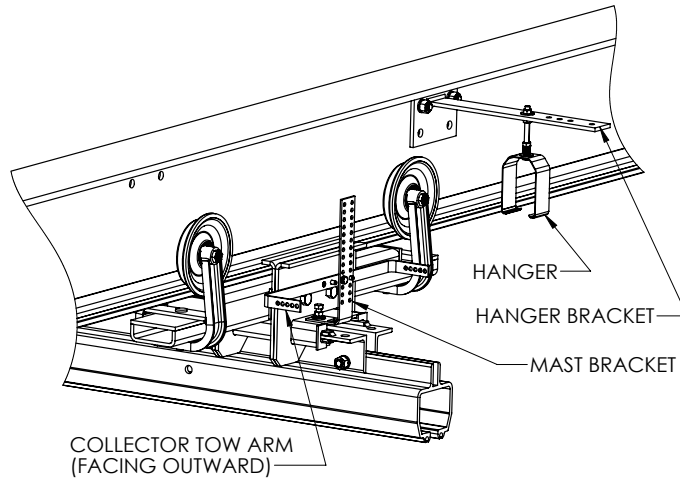

Diagram 10A. Short Sleeve Endtruck

➡ **NOTE:** If facing inward the inmost hole of the hanger bracket is used (**Diagram 10B**). If oriented outward for long sleeve endtrucks, the hanger is mounted to the outermost hole of the hanger bracket.

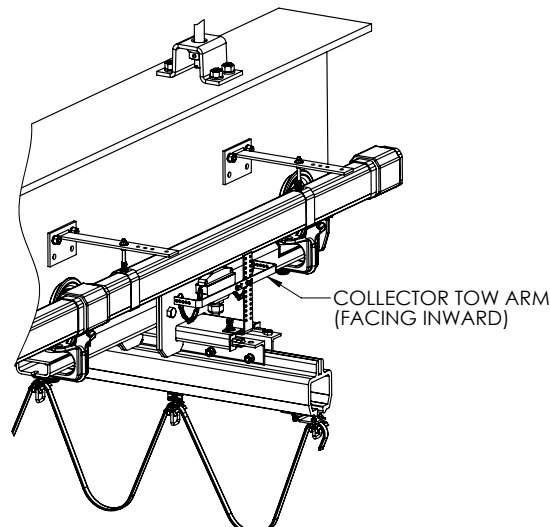

Diagram 10B. Long Sleeve Endtruck

STEP 10 - ELECTROBAR ELITE CONDUCTOR BAR (OPTIONAL) CONT'D

10.2 Determine the quantity and location of hanger brackets. The Electrobar Elite is supplied in 1, 2, and 4 meter lengths to comprise the length of the runway. A piece may need to be trimmed. Refer to the [Magnetec Electrobar Elite Instruction Manual](#). Starting with the power feed, lay out the conductor bar along the runway, going from the longest 4-meter pieces down to the shortest pieces. The runway Tarca® rail is pre-punched with mounting holes for the hangers. These hole sets are at approximately 17-1/2" from the end of each runway section and evenly spaced (35" maximum spacing) along the length of the runway. Per Magnetec instructions, the conductor bar requires support within 14" from its ends and at each joint. Hanger spacing should not exceed 79" and conductor bar sections 1.5 meters and above in length require a minimum of 2 hangers. Align the conductor sections with the runway to accommodate the hanger requirements.

NOTE: Due to the loss of end approach of the bridge from the endstop and half the entruck length, the conductor bar does not need to extend to the end of the runway.

NOTE: Joint covers are 6" long and hangers are 1-1/2" wide. Therefore, a hole set needs to be between 14" and 3-3/4" from a conductor bar splice connection. Align and/or rearrange conductor bar sections so that they can be mounted at required locations. It may be necessary to drill extra mounting holes in the runway (**Diagram 10C**).

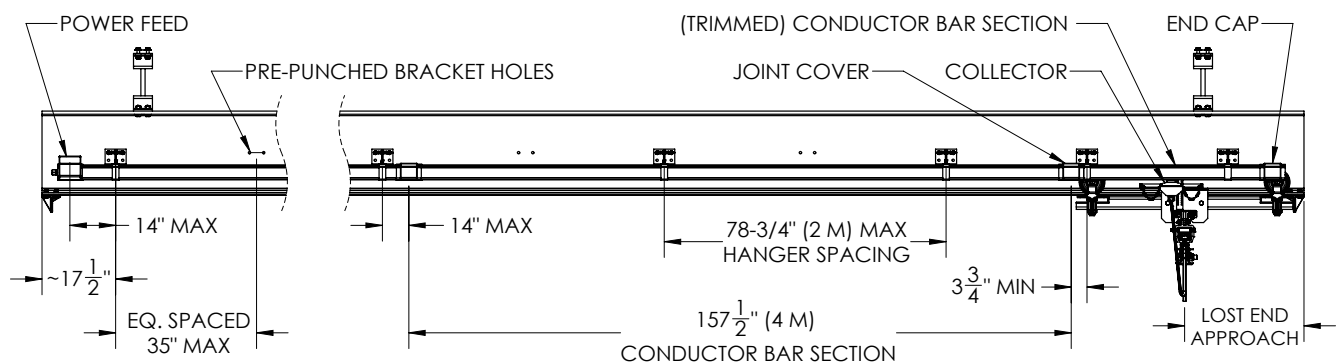

Diagram 10C. Conductor Bar Layout

10.3 Attach hangers to brackets and brackets to Tarca rail. Use innermost or outermost hole as determined in Step 10.1. Use runway hole locations as determined in Step 10.2.

NOTE: Two fixed hangers are supplied. These are to be mounted at the inner most bracket locations on the runway (**Diagram 10D**).

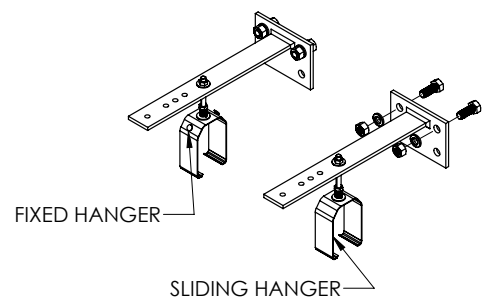

Diagram 10D. Hanger & Hanger Bracket

STEP 10 - ELECTROBAR ELITE CONDUCTOR BAR (OPTIONAL) CONT'D

- **NOTE:** For free standing systems with short depth runways and short bridges, the hanger bracket may interfere with the column gusset. Reduce the length of this bracket to prevent interference (*Diagram 10E*).

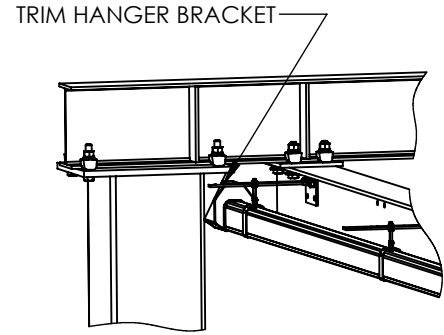

Diagram 10E. Hanger Bracket Interference

- 10.4 Follow instructions in the Magnetec Electrobar Elite Instruction Manual to complete conductor bar installation.
- 10.5 Attach mast bracket (from tow arm kit) to end of bridge sleeve on endtruck by replacing clamping bolt with longer 3/8" bolt and adding mast bracket, flat washer, and lock washer. Tighten bolt to lock endtruck to bridge. Square up mast alignment tab to sleeve and tighten nut until lock washer is fully compressed (*Diagram 10F*).

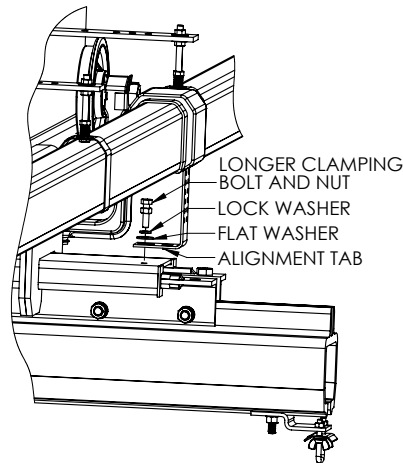

Diagram 10F. Tow Arm Mast Bracket

- 10.6 Attach tow arm to mast bracket as determined in Step 10.1 and inline with chains on collector.

- **NOTE:** Offset tow arm to the side to allow for cable drop from collector to festoon clamp on bridge. Attach chains on collector to tow arm (*Diagram 10G*).

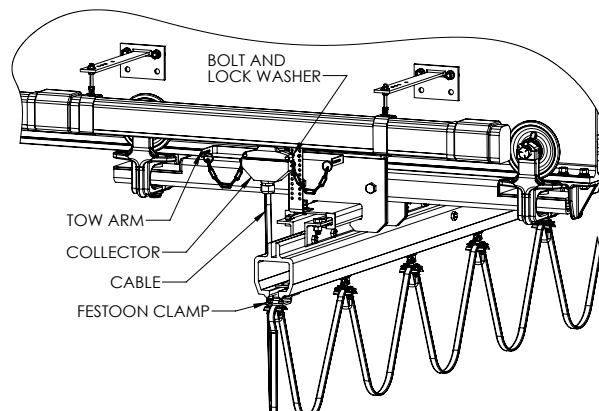

Diagram 10G. Tow Arm & Collector

STEP 10 - ELECTROBAR ELITE CONDUCTOR BAR (OPTIONAL) CONT'D

Bridge Conductor Bar Installation

10.7 Attach tow arm bracket to trolley. For a load bar trolley: remove nylock nut and reinstall with tow arm bracket. For trolley: attach anti-rotation hardware to bracket, remove clevis pin and replace with clevis bolt.

NOTE: Place flat washer(s) as needed behind head of clevis bolt to center hook saddle between trolley side plates. Assemble tow arm bracket, washer, and slotted nut. Tighten slotted nut until snug. Overtightening will distort trolley boy. Install cotter pin through slots in nut and hole in bolt to lock (**Diagram 10H**).

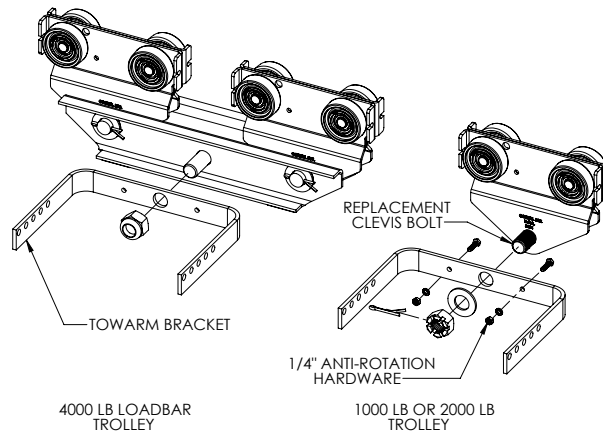

Diagram 10H. Tow Arm Bracket Installed on Trolley

10.8 Determine if bridge endstop mounting requires relocating. For a 1000# or 2000# trolley to reach its full travel with the standard end approach loss, the power feed and wire on the conductor bar will need to extend beyond the end of the bridge by approximately 4-1/2" (**Diagram 10J**). For a ceiling mounted system, verify that the bridge will be in compliance with the OSHA required clearance of 2", if the power feed side of the conductor bar extends 4-1/2" beyond the bridge length. If necessary, limit the length of the bridge conductor bar and drill a new 17/32" diameter thru hole for mounting the endstop to prevent the conductor bar collector from impacting the power feed. For free standing systems, the power feed and wire cannot extend beyond the bridge. Drilling the aluminum bridge and relocating the endstop by a minimum of 4-1/2" is required.

NOTE: For 4000# trolleys, the standard loss of end approach (distance from the end of the bridge to the hoist hook) is 15-1/8", which should provide sufficient room for the power end feed without modification of the hoist trolley endstop mounting location.

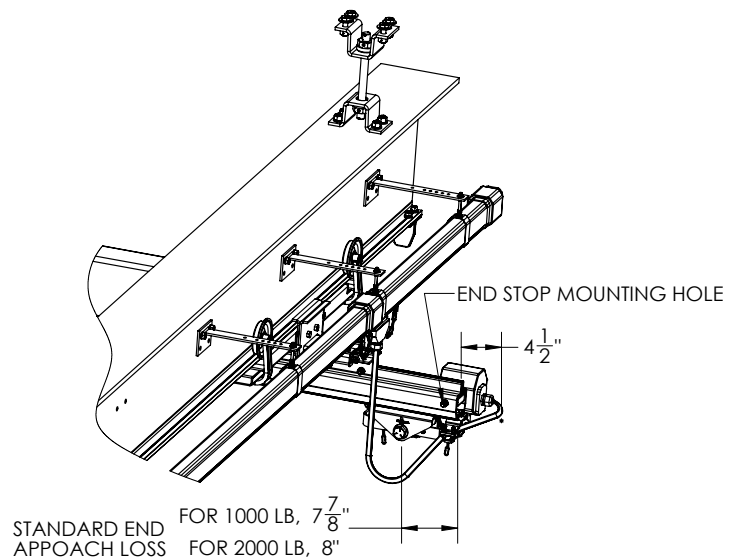

Diagram 10J. Clearance Check for Moving Bridge Conductor Bar

STEP 10 - ELECTROBAR ELITE CONDUCTOR BAR (OPTIONAL) CONT'D

10.9 Determine distance for adjustable hanger bracket so that hanger centerline will be directly above first hole in tow arm bracket (**Diagram 10K**). Web thickness can vary from 1/4" to 1/2". Load bar is 3/16" thick.

Example: 1000# capacity trolley with a 1/4" web thickness will require a bracket length of 5-7/16" minus half of 1/4". Which equals 5-5/16".

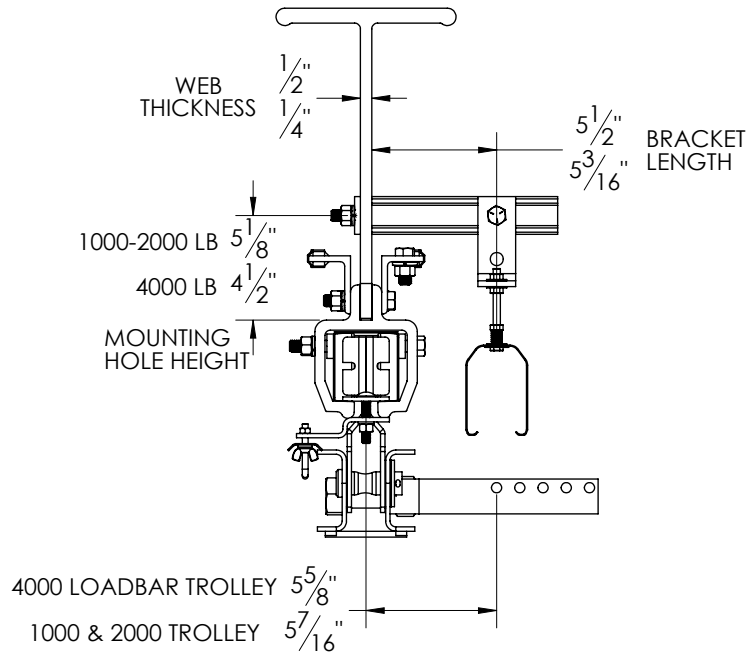

Diagram 10K. Hanger Bracket Adjustment Length & Height

10.10 Assemble hanger brackets and hangers (**Diagram 10L**). End hangers should be assembled to minimize cantilever of conductor bar. It may be necessary to mount a hanger to the endtruck (**Diagram 10M**) to minimize overhang.

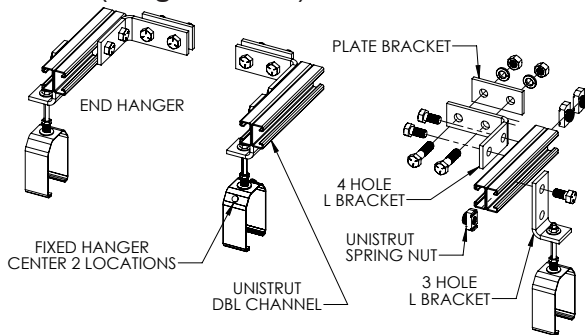

Diagram 10L. Hanger & Bracket Assembly

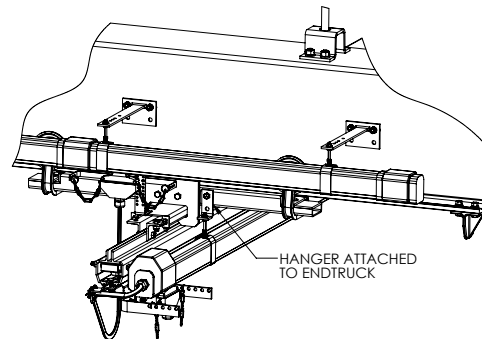

Diagram 10M. Bridge & Runway Conductor Bar End View

10.11 Layout and trim conductor bar for bridge as required per the Magnetex Electrobar Elite Instruction Manual. Drill aluminum web of bridge for 1/2" conductor hanger bar bracket hardware at height shown (**Diagram 10K**). Bracket holes are 1-7/8" apart.

10.12 Mount brackets and complete installation per Magnetec Electrobar Elite Instruction Manual.

STEP 11 - SAFE-LEC 2 CONDUCTOR BAR (OPTIONAL)

WARNING

Conductor Bar must be installed on the outboard side of the runway to not interfere with the coped two-piece aluminum bridge.

11.1 Attach four bar hanger and anchor clamps to the hanger bracket. The bracket has hole patterns as shown in **Diagram 11A**. Bolt conductor bar hangers to brackets (**Diagram 11B**).

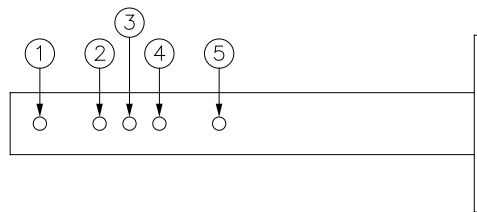
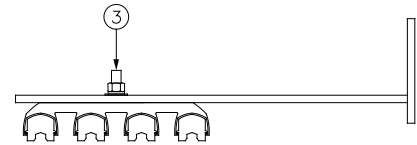
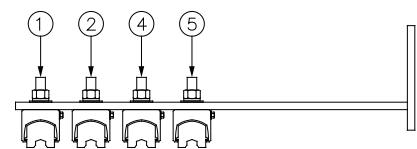

Diagram 11A.



Four bar hanger.



Anchor clamps for 4-bar set-up.

Diagram 11B.

NOTE: With a free standing system and shorter height runway, it may be necessary to modify the hanger. To allow for clearance at the column gussets, conductor bars may need to be relocated by a bar width. Drill an additional hole in the hanger brackets (**Diagram 11C**). If brackets are mounted at a column, they will also need to be trimmed along with the tow arm (**Diagram 11D**).

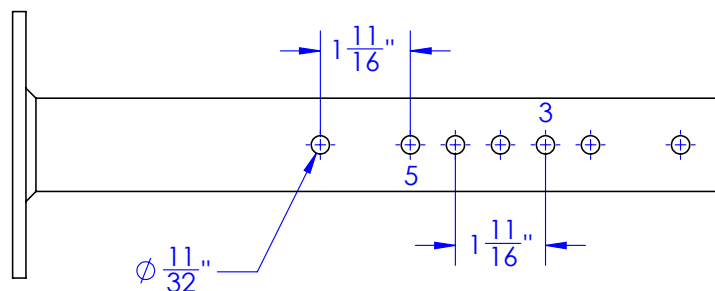

Diagram 11C.

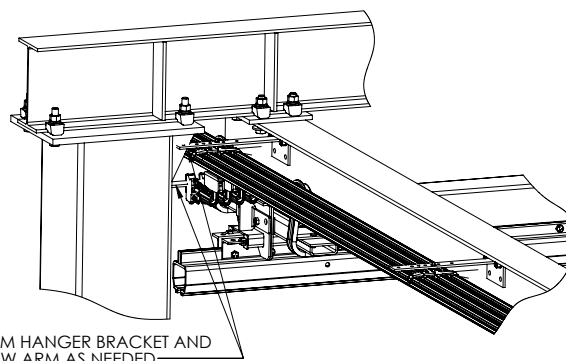

Diagram 11D. Possible Hanger Bracket & Tow Arm Interference

STEP 11 - SAFE-LEC 2 CONDUCTOR BAR (OPTIONAL) CONT'D

- 11.2** Each system requires the use of anchor clamps. The anchor clamps will replace one regular conductor bar hanger and serve to prevent the bars from sliding back and forth on the runways. These anchor clamps should be placed in the center of the conductor bar system (**Diagram 11E**).

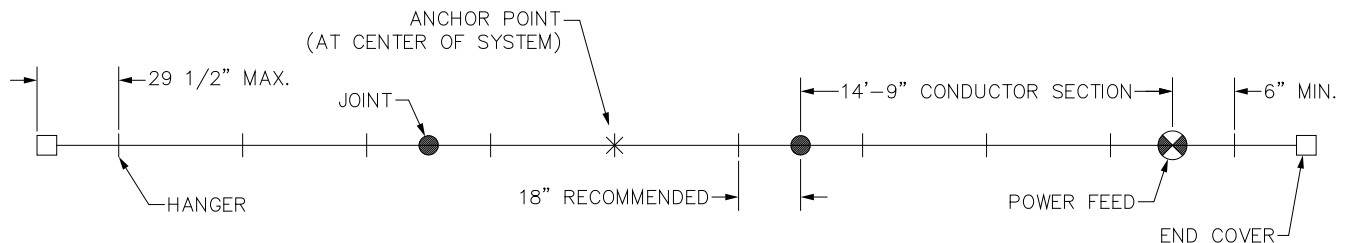

Diagram 11E. Typical conductor bar.

- 11.3** The hanger bracket can be mounted two ways, in a “high” or in a “low” position. This orientation depends on the rail. For light rail (Tarca 4500 and 4600), brackets are mounted in the “high” position. For heavy rail (Tarca 5000 and higher), brackets are mounted in the “low” position. Bolt hanger brackets to web of runway with 1/2” hardware (**Diagram 11F**).

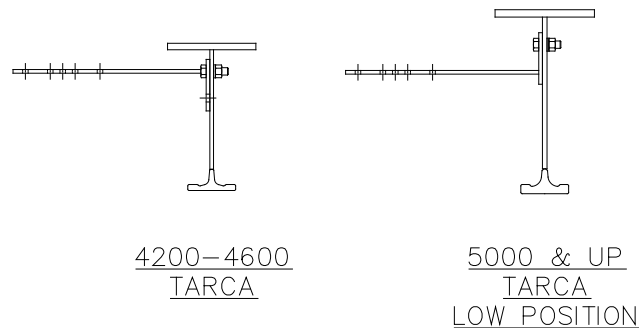

Diagram 11F. Conductor bar mounting bracket.

STEP 11 - SAFE-LEC 2 CONDUCTOR BAR (OPTIONAL) CONT'D

11.4 Install tow arm bracket and tow arm to endtruck.

NOTE: When assembling the endtruck in Step 5.4, add the tow arm and bracket (*Diagram 11G*). Note the low position of the tow arm for 1000# capacity endtrucks and the high position for 2000# and 4000# endtrucks. For 1000# capacity, the 1/2"-13 bolt is 6" long instead of the standard 5-3/4" in length.

WARNING

This step must be performed prior to installing the bridge on the runway.

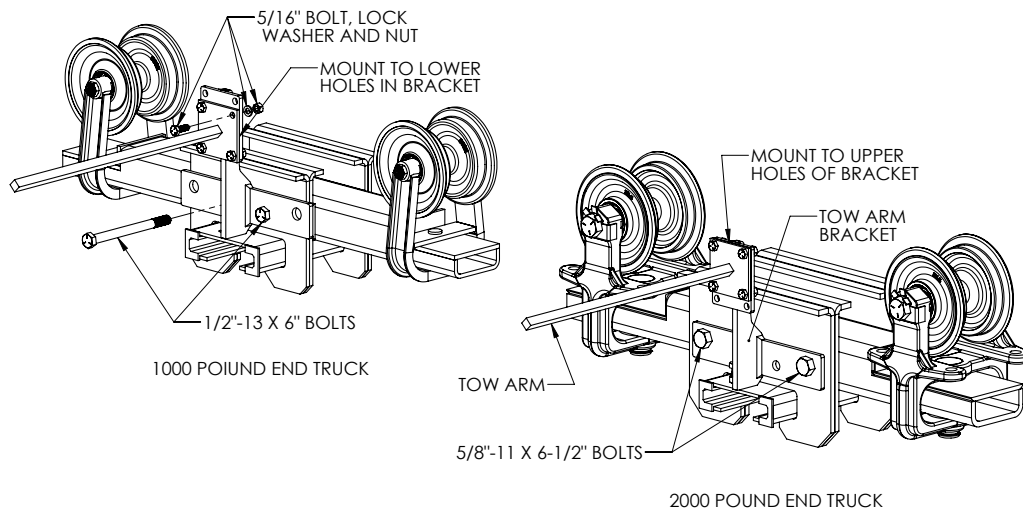

Diagram 11G. Tow Arm Installation to Endtruck

11.5 Slide the collectors onto the tow arm and position them to line up under their corresponding conductor bar (*Diagram 11H*). Tighten collector bolts to clamp in place.

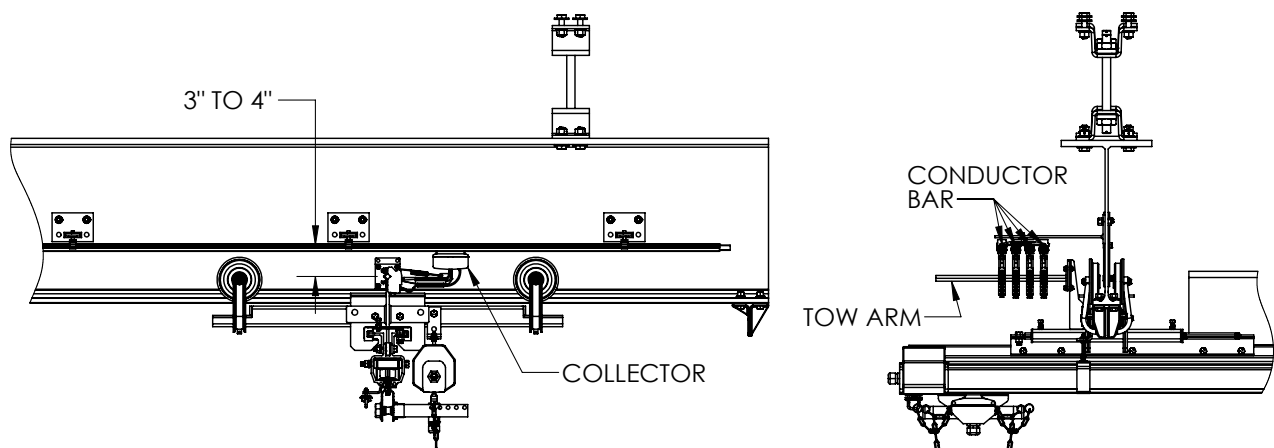

Diagram 11H. Collector Installation on Tow Arm

STEP 11 - SAFE-LEC 2 CONDUCTOR BAR (OPTIONAL) CONT'D

- 11.6** Run 4COND 12AWG to 14AWG SO(W) (recommended) cable from collectors to power feed of bridge conductor bar or run bridge festton cable to collectors.
- 11.7** Strip the end of the collector wire and insert into the collector (**Diagram 11J**).
- 11.8** Clamp the wire with the two screws. The plastic screw should tighten down on the wire's insulation. When tightening the clamping screw there will be some resistance. Keep tightening until the wire is clamped firmly in place.

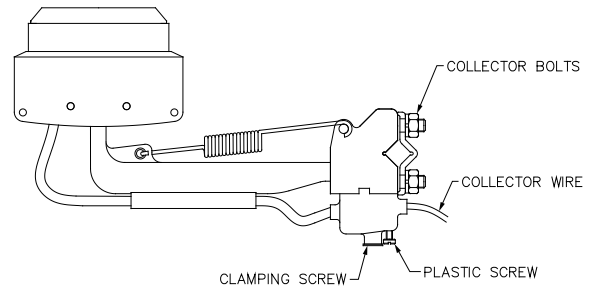

Diagram 11J.

STEP 12 - FINAL STEPS

- 12.1 Be sure to sway brace the crane as required. Refer to Sway and Thrust Bracing Guidelines (**Step 13**).
- 12.2 Verify that all bolts are tightened to specifications and lockwashers are compressed.
- 12.3 Be sure all endstops are installed and functional.
- 12.4 Verify that the power supply is in conformance with crane specifications as ordered.
- 12.5 Load test is required (by others). It should be performed per latest ANSI B30.11 specification.
- 12.6 If necessary, touch up crane with paint provided.

➡ **TIP:** Do not throw away this manual: the maintenance schedule is on the back cover. Keep Packing List, Installation Manual, General Arrangement Drawing, and any other inserts filed together in a safe place.

SWAY BRACE (OPTIONAL) GUIDELINES - FREE STANDING

NOTE: SWAY BRACING BY OTHERS

Support assemblies are designed to AISC (American Institute of Steel Construction) specifications. If reduced movement of support assemblies is desired, then sway bracing (not included) can be added. The installer or end user must determine the possible locations of the bracing based on the specific application.

Bracing can be added in one of three formats, or a combination of any three.

A) The most typical place to brace is directly to a building column. Providing a brace from a building column to the lateral (side) and longitudinal (lengthwise) axis of the support steel provided extreme rigidity throughout the system, and requires only minimal locations (2 or 3 corners of the system is typically adequate, see 'A' in **Diagram 13A**).

B) Another method is to brace back to the ceiling above the crane. Again, bracing at the corners of the system in both a lateral and longitudinal direction is sufficient (see 'B' in **Diagram 13A**), providing the distance to the ceiling is not greater than 10 feet. For distances greater than 10 feet, additional points may need to be braced both laterally and longitudinally at the discretion of the end user and/or the installer.

C) Finally, if the system is located at a point where it is not practical or possible to brace to the building columns or the ceiling structure, cross bracing can be done. This can be added at the sides of the system (see 'C' in **Diagram 13A**) to control longitudinal sway, or across the open ends to limit lateral motion (not shown). This can also be added to the top of the system, but should be checked to make sure that it does not interfere with the travel of the bridge.

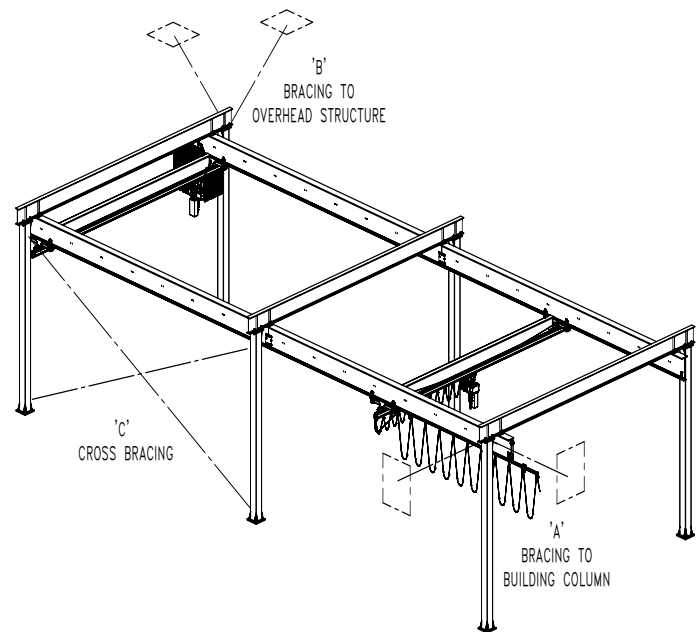

Diagram 13A. Examples of typical sway bracing locations.

It should be noted that the use of sway bracing is purely subjective because it is not a requirement of Gorbels, Inc. No specifications exist detailing appropriate methods, and the ultimate quantity and type is at the discretion of the user and installer. **If bracing, always determine if the building structure is adequate.**

WARNING

If bracing, brace to the headers not the columns.

SWAY BRACE GUIDELINES - CEILING SUPPORTED

NOTE: SWAY LIMITING BRACING BY OTHERS, INSTALLED AS REQUIRED.

WARNING

Bracing must be installed to resist damaging lateral and longitudinal loads.

After flexibly suspended runway rail has been adjusted to its proper height and leveled, mechanical restrictions must be added to the system to limit the sway of the hanger rods. If the system were allowed to move excessively stresses would be created throughout the entire installation causing permanent damage to the components. This anti-sway bracing must be installed to limit the movement of the system both laterally and longitudinally.

The function of the sway limiting bracing is solely to limit the movement of the material handling system. It cannot be used to force runways into alignment. All rails must be aligned and leveled before anti-sway bracing is installed. Also, the bracing cannot be allowed to carry any of the load supported by the hanger rods. The flexible system is designed to absorb the forces of movement and inertia. If these forces are allowed to act upon the sway bracing their full force will be transmitted to the building or superstructure.

Sway limiting bracing must be installed so that it does not interfere with or restrict the normal expansion or contraction of the system. Both runways must be longitudinally braced. Only one of the runways is to be laterally braced.

The other runway must be left free to float laterally to provide relief for variations in runway alignment, crane deflections and building variations. Lateral braces are to be installed at each suspension point. If the support center/top flange width ratio exceeds 40:1, additional lateral bracing is required.

Where the runways are suspended from a building with a sloping roof, the bracing must be attached to the runway having the shorter hanger rods. For cranes, only one runway is required to be laterally sway braced, however, both runways must be longitudinally braced. Lateral bracing should be no further than two flange widths from a hanger rod.

The lateral force on crane runways to provide for the effect of moving crane trolleys shall, if not otherwise specified, be 20 percent of the sum of the weights of the lifted load and of the crane trolley (but exclusive of other parts of the crane). The force shall be assumed to be applied at the bottom of the laterally braced runway, and shall be considered as acting in either direction normal to the runway rail.

The longitudinal force shall, if not otherwise specified, be taken as 10 percent of the maximum wheel loads of the crane applied at the bottom of rail.

CRANE OPERATOR INSTRUCTIONS

Overhead Patented Track cranes generally handle materials over working areas where there are personnel. Therefore, it is important for the Crane Operator to be instructed in the use of the crane and to understand the severe consequences of careless operation. It is not intended that these suggestions take precedence over existing plant safety rules and regulations or OSHA regulations. However, a thorough study of the following information should provide a better understanding of safe operation and afford a greater margin of safety for people and machinery on the plant floor. It must be recognized that these are suggestions for the Crane Operator's use. It is the responsibility of the owner to make personnel aware of all federal, state and local rules and codes, and to make certain operators are properly trained.

Qualifications

Crane operation, to be safe and efficient, requires skill: the exercise of extreme care and good judgement, alertness and concentration, and rigid adherence to proven safety rules and practices as outlined in applicable and current ANSI and OSHA safety standards. In general practice, no person should be permitted to operate a crane:

- Who cannot speak the appropriate language or read and understand the printed instructions.
- Who is not of legal age to operate this type of equipment.
- Whose hearing or eyesight is impaired (unless suitably corrected with good depth perception).
- Who may be suffering from heart or other ailments which might interfere with the operator's safe performance.
- Unless the operator has carefully read and studied this operation manual.
- Unless the operator has been properly instructed.
- Unless the operator has demonstrated his instructions through practical operation.
- Unless the operator is familiar with hitching equipment and safe hitching equipment practices.

Handling the Trolley Motion

Before a load is handled, the hoist should be positioned directly over the load that is to be handled. When the slack is taken out of the slings, if the hoist is not directly over the load, bring it directly over the load before hoisting is continued. Failure to center the hoist over the load may cause the load to swing upon lifting. Always start the trolley motion slowly and reduce the trolley speed gradually.

Handling the Hoist Motion

Refer to the lifting (hoist) equipment's operating instructions.

GENERAL SUGGESTIONS

Know Your Crane

Crane operators should be familiar with the principal parts of a crane and have a thorough knowledge of crane control functions and movements. The crane operator should be required to know the location and proper operation of the main conductor disconnecting means for all power to the attachments on the crane.

Responsibility

Each crane operator should be held directly responsible for the safe operation of the crane. Whenever there is any doubt as to SAFETY, the crane operator should stop the crane and refuse to handle loads until: (1) safety has been assured or (2) the operator has been ordered to proceed by the supervisor, who then assumes all responsibility for the SAFETY of the lift.

Do not permit **ANYONE** to ride on the hook or a load.

Inspection

Test the crane movement and any attachments on the crane at the beginning of each shift. Whenever the operator finds anything wrong or apparently wrong, the problem should be reported immediately to the proper supervisor and appropriate corrective action taken.

Operating Suggestions

One measure of a good crane operator is the smoothness of the crane operation. The good crane operator should know and follow these proven suggestions for safe, efficient crane handling.

1. The crane should be moved smoothly and gradually to avoid abrupt, jerky movements of the load. Slack must be removed from the sling and hoisting ropes before the load is lifted.
2. Center the crane over the load before starting the hoist to avoid swinging the load as the lift is started. Loads should not be swung by the crane to reach areas not under the crane.
3. Crane-hoisting ropes should be kept vertical. Cranes shall not be used for side pulls.
4. Be sure everyone in the immediate area is clear of the load and aware that a load is being moved.
5. Do not make lifts beyond the rated load capacity of the crane, sling chains, rope slings, etc.
6. Make certain that before moving the load, load slings, load chains, or other lifting devices are fully seated in the saddle of the hook with hook latch closed (if equipped with hook latch).
7. Check to be sure that the load and/or bottom block is lifted high enough to clear all obstructions when moving boom or trolley.
8. At no time should a load be left suspended from the crane unless the operator has the push button with the power on, and under this condition keep the load as close as possible to the floor to minimize the possibility of an injury if the load should drop. When the crane is holding a load, the crane operator should remain at the push button.
9. Do not lift loads with sling hooks hanging loose. If all sling hooks are not needed, they should be properly stored, or use a different sling.
10. All slings or cables should be removed from the crane hooks when not in use (dangling cables or hooks hung in sling rings can inadvertently snag other objects when the crane is moving).
11. Operators shall not carry loads and/or empty bottom blocks over personnel. Particular additional caution should be practiced when using magnet or vacuum devices. Loads, or parts of loads, held magnetically could drop. Failure of power to magnets or vacuum devices can result in dropping the load. Extra precaution should be exercised when handling molten metal in the proximity of personnel.
12. Whenever the operator leaves the crane the following procedure should be followed:
 - Raise all hooks to an intermediate position.
 - Spot the crane at an approved designated location.
 - Place all controls in the "off" position.
 - Open the main switch to the "off" position.
 - Make visual check before leaving the crane.
13. In case of emergency or during inspection, repairing, cleaning or lubrication, a warning sign or signal should be displayed and the main switch should be locked in the "off" position. This should be done whether the work is being done by the crane operator or by others.
14. Contact with rotation stops or trolley end stops shall be made with extreme caution. The operator should do so with particular care for the safety of persons below the crane, and only after making certain that any persons on the other cranes are aware of what is being done.
15. ANY SAFETY FEATURES AND MECHANISMS BUILT IN OR OTHERWISE PROVIDED WITH THE CRANE BY CLEVELAND TRAMRAIL ARE REQUIRED FOR THE SAFE OPERATION OF THE CRANE. DO NOT, UNDER ANY CIRCUMSTANCES, REMOVE OR OTHERWISE IMPAIR OR DISABLE THE PROPER FUNCTIONING OF ANY CRANE SAFETY MECHANISMS OR FEATURES BUILT-IN OR OTHERWISE PROVIDED BY CLEVELAND TRAMRAIL FOR SAFE OPERATION OF THE CRANE. ANY REMOVAL, IMPAIRMENT OR DISABLING OF ANY SUCH SAFETY MECHANISMS OR FEATURES OR OTHER USE OR OPERATION OF THE CRANE WITHOUT THE COMPLETE AND PROPER FUNCTIONING OF ANY SUCH SAFETY MECHANISMS OR FEATURES AUTOMATICALLY AND IMMEDIATELY VOIDS ANY AND ALL EXPRESS AND IMPLIED WARRANTIES OF ANY KIND OR NATURE.

LIMITED WARRANTY

It is agreed that the equipment purchased hereunder is subject to the following LIMITED warranty and no other. Gorbel warrants the manual or motorized Patented Track Crane products to be free from defects in material or workmanship for a period of two years or 4,000 hours use from date of shipment in class C service. This warranty shall not cover failure or defective operation caused by operation in excess of recommended capacities, misuses, negligence or accident, and alteration or repair not authorized by Gorbel. No system shall be field modified after manufacture without the written authorization of Gorbel, Inc. Any field modification made to the system without the written authorization of Gorbel, Inc. shall void Gorbel's warranty obligation. OTHER THAN AS SET FORTH HEREIN, NO OTHER EXPRESS WARRANTIES, AND NO IMPLIED WARRANTIES, ORAL OR WRITTEN, INCLUDING BUT NOT LIMITED TO THE WARRANTIES OF MERCHANTABILITY OR FITNESS FOR A PARTICULAR PURPOSE, ARE MADE BY GORBEL WITH RESPECT TO ITS PRODUCTS AND ALL SUCH WARRANTIES ARE HEREBY SPECIFICALLY DISCLAIMED. GORBEL SHALL NOT BE LIABLE UNDER ANY CIRCUMSTANCES FOR ANY INCIDENTAL, SPECIAL AND/OR CONSEQUENTIAL DAMAGES WHATSOEVER, WHETHER OR NOT FORESEEABLE, INCLUDING BUT NOT LIMITED TO DAMAGES FOR LOST PROFITS AND ALL SUCH INCIDENTAL, SPECIAL AND/OR CONSEQUENTIAL DAMAGES ARE HEREBY ALSO SPECIFICALLY DISCLAIMED. Gorbel's obligation and Purchaser's or end user's sole remedy under this warranty is limited to the replacement or repair of Gorbel's products at the factory, or at the discretion of Gorbel, at a location designated by Gorbel. Purchaser or end user shall be solely responsible for all freight and transportation costs incurred in connection with any warranty work provided by Gorbel hereunder. Gorbel will not be liable for any loss, injury or damage to persons or property, nor for damages of any kind resulting from failure or defective operation of any materials or equipment furnished hereunder. Components and accessories not manufactured by Gorbel are not included in this warranty. Purchaser's or end user's remedy for components and accessories not manufactured by Gorbel is limited to and determined by the terms and conditions of the warranty provided by the respective manufacturers of such components and accessories.

A) DISCLAIMER OF IMPLIED WARRANTY OF MERCHANTABILITY

Gorbel and Purchaser agree that the implied warranty of merchantability is excluded from this transaction and shall not apply to the goods involved in this transaction.

B) DISCLAIMER OF IMPLIED WARRANTY OF FITNESS FOR PARTICULAR PURPOSE

Gorbel and Purchaser agree that the implied warranty of fitness for particular purpose is excluded from this transaction and shall not apply to the goods involved in this transaction.

C) DISCLAIMER OF EXPRESS WARRANTY

Gorbel's agents, or dealer's agents, or distributor's agents may have made oral statements about the machinery and equipment described in this transaction. Such statements do not constitute warranties, and Purchaser agrees not to rely on such statements. Purchaser also agrees that such statements are not part of this transaction.

D) DISCLAIMER OF SPECIAL, INCIDENTAL AND CONSEQUENTIAL DAMAGES

Gorbel and Purchaser agree that any claim made by Purchaser which is inconsistent with Gorbel's obligations and the warranty remedies provided with Gorbel's products, and in particular, special, incidental and consequential damages, are expressly excluded.

E) DEALER OR DISTRIBUTOR NOT AN AGENT

Gorbel and Purchaser agree that Purchaser has been put on notice that dealer or distributor is not Gorbel's agent in any respect for any reason. Gorbel and Purchaser also agree that Purchaser has been put on notice that dealer or distributor is not authorized to incur any obligations or to make any representations or warranties on Gorbel's behalf other than those specifically set forth in Gorbel's warranty provided in connection with its product.

F) MERGER

This warranty agreement constitutes a final and complete written expression of all the terms and conditions of this warranty and is a complete and exclusive statement of those terms.

G) PAINTING

Every crane (excluding components) receives a quality paint job before leaving the factory. Unfortunately, no paint will protect against the abuses received during the transportation process via common carrier. We have included at least one (1) twelve ounce spray can for touchup with each crane ordered (unless special paint was specified). If additional paint is required, contact a Gorbel® Customer Service Representative at 1-800-821-0086 or 1-585-924-6262.

Title and Ownership:

Title to the machinery and equipment described in the foregoing proposal shall remain with Gorbel and shall not pass to the Purchaser until the full amount herein agreed to be paid has been fully paid in cash.

Claims and Damages:

Unless expressly stated in writing, goods and equipment shall be at Purchaser's risk on and after Seller's delivery in good shipping order to the Carrier. Gorbel shall in no event be held responsible for materials furnished or work performed by any person other than it or its authorized representative or agent.

Cancellations:

If it becomes necessary for the purchaser to cancel this order wholly or in part, he shall at once so advise Gorbel in writing. Upon receipt of such written notice all work will stop immediately. If the order entails only stock items, a flat restocking charge of 15% of the purchase price will become due and payable by Purchaser to Gorbel. Items purchased specifically for the canceled order shall be charged for in accordance with the cancellation charges of our supplier plus 15% for handling in our factory. The cost of material and/or labor expended in general fabrication for the order shall be charged for on the basis of total costs to Gorbel up to the time of cancellation plus 15%.

Returns:

No equipment, materials or parts may be returned to Gorbel without express permission in writing to do so.

Extra Charge Delay: If Purchaser delays or interrupts progress of Seller's performance, or causes changes to be made, Purchaser agrees to reimburse Gorbel for expense, if any, incident to such delay.

Changes and Alterations:

Gorbel reserves the right to make changes in the details of construction of the equipment, as in its judgment, will be in the interest of the Purchaser; will make any changes in or additions to the equipment which may be agreed upon in writing by the Purchaser; and Gorbel is not obligated to make such changes in products previously sold any customer.

Third Party Action:

Should Gorbel have to resort to third party action to collect any amount due after thirty (30) days from date of invoice, the Purchaser agrees to pay collection costs, reasonable attorney's fees, court costs and legal interest.

OSHA Responsibilities:

Gorbel agrees to fully cooperate with Purchaser in the design, manufacture or procurement of safety features or devices that comply with OSHA regulations. In the event additional equipment or labor shall be furnished by Gorbel, it will be at prices and standard rates then in effect, or as may be mutually agreed upon at the time of the additional installation.

Equal Employment Opportunity:

Gorbel agrees to take affirmative action to ensure equal employment opportunity for all job applicants and employees without regard to race, color, age, religion, sex, national origin, handicap, veteran, or marital status. Gorbel agrees to maintain non-segregated work facilities and comply with rules and regulations of the Secretary of Labor or as otherwise provided by law or Executive Order.

INSPECTION AND MAINTENANCE SCHEDULE

The following is a checklist to be followed in performing periodic inspections and preventative maintenance on Gorbel® Tarca® Hybrid Systems. It is intended that this checklist be supplemented with any additional instruction sheets and maintenance manuals sent with each job.

The frequency of inspection and lubrication recommendations presented herein is based upon normal operating conditions of one complete handling cycle every 10 minutes throughout a 40-hour week. If the actual duty cycle of a particular unit is greater or less than this, the inspections and lubrications should be performed more frequently or less frequently in proportion.

Each industry has conditions peculiar to it, which may cause wear of certain parts. The tabulation given is only general and may be supplemented by an individual maintenance department program to meet its own particular requirements. Particular attention should be given to corrosive conditions, excessive vibrations, extreme ambient temperature variations, and rough handling conditions.

Questions regarding damaged, worn or cracked equipment components should be directed to the Gorbel® Inside Sales Department at 800-821-0086 or 585-924-6262.

The recommendations contained herein are to be supplemented by any vendor instructions, which are included in this manual.

WARNING

Power should be off and locked when performing maintenance on any part of the system.

* State and local codes may require inspection and maintenance checks more often. Please check the state and local code manuals in your area.

TRACKS, RUNWAYS & HANGERS or SUPPORT STEEL

ITEM	COMPONENT	MAINTENANCE	FREQUENCY
1	Top Hanger Bracket/ Beam Clips/ Threaded Rod	Check that lock washers are compressed and nuts tightened to manufacturer's specifications.	Every 1,000 hours or 6 months
2	Lower Hanger Bracket (Ceiling Supported)	Check that lock washers are compressed and nuts tightened to manufacturer's specifications.	Every 1,000 hours or 6 months
3	Header-Column Hardware (Free Standing)	Check for loose bolts & cracked fittings. Check for full compression of lock washer. Bolt should be tightened to manufacturer's specifications.	Every 1,000 hours or 6 months
4	Header-Runway Hardware (Free Standing)	Check for loose bolts & cracked fittings. Check for full compression of lock washer. Bolt should be tightened to manufacturer's specifications.	Every 1,000 hours or 6 months
5	Column Anchoring (Free Standing)	Check for loose bolts & cracked fittings.	Every 1,000 hours or 6 months
6	Sway Brace Connection (Optional on Free Standing Systems)	Check for loose bolts & cracked fittings.	Every 1,000 hours or 6 months

TRACKS, RUNWAYS & HANGERS or SUPPORT STEEL (CONTINUED)

ITEM	COMPONENT	MAINTENANCE	FREQUENCY
7	Track	Check for rail wear (replace if raised portion of tread is gone). Check welds for incipient cracks. Check underside of rail for wear from drive rollers if using tractor drives. When groove is 1/8" deep, replace track. Check side of rail for wear. When width has decreased more than 1/8", replace track.	Every 2,000 hours or yearly
8	Joints	Check for loose or worn hardware or if welded type, for incipient cracks. Check for track alignment and that wheel rolling surface is flush.	Every 2,000 hours or yearly
9	End stops	Check for loose bolts and for incipient cracks.	Every 2,000 hours or yearly
10	Paint	Clean periodically and repaint where corrosion is present.	Every 2,000 hours or yearly

ENDTRUCKS

ITEM	COMPONENT	MAINTENANCE	FREQUENCY
11	Support Weldment & Tube Weldment	Check for incipient cracks in welds. Check for loose bolts.	Every 2,000 hours or yearly
12	Wheels	Check for loose wheel bearings. Check wheels for proper contact and tracking on rail. Check wheel diameter for wear (replace when 1/4" under original diameter). Check axle nuts for tightness. Lubricate using Calcium Sulfonate type grease (Peerless OG2 Red or equal).	Every 500 hours or 3 months
13	Idler Heads	Check for thrust washer wear and integrity. Lubricate with a spray or general purpose oil.	Every 1,000 hours or 6 months

BRIDGE

ITEM	COMPONENT	MAINTENANCE	FREQUENCY
14	Hoist Trolley	Check clevis pin. Check cotter pin. (Cotter pin should be fully wrapped around clevis pin.) Check clevis bolt and hardware.	Every 2,000 hours or yearly
15	Endstops	Check for full compression of lock washer. If thru-bolt is exposed, replace endstops.	Every 2,000 hours or yearly
16	Festoon Cable Clamp or Vacuum Hose Clamp	Check for full compression of lock washer.	Every 2,000 hours or yearly
17	Trolley Wheels	Check for cracks, pits, and/or grooves: All of these increase pull forces. If any of these conditions exist, wheels should be replaced.	Every 2,000 hours or yearly
18	Aluminum Bridge Assembly Hardware	Check that lock washers are compressed and nuts tightened to 50 ft-lbs of torque. Ensure sheer lug hardware is still in required position and tight.	Every 2,000 hours or yearly

SAFE-LEC CONDUCTOR BAR

ITEM	COMPONENT	MAINTENANCE	FREQUENCY
19	Collectors	Contact shoes should be checked for wear. Check alignment of collector to conductor bar. Base of collector should be directly inline with associated conductor. Check collector pivot pins are free from any contamination. Uneven shoe wear indicates less than optimal collector alignment.	Every 150 hours or 1 month
20	Bar Covering	Check to ensure no damage is visible.	Every 2,000 hours or yearly
21	Complete System	In environments that are subject to considerable build up of dust, especially conductive dust, remove this dust by brushing.	Every 2,000 hours or yearly

HOIST (Refer to Hoist Manufacturer's Manual)

WARNING

Any changes in rolling effort or unusual noises must be immediately identified and corrected. It is not necessary to lubricate the track or bearings. Lubricating may attract airborne particles and may increase the rolling resistance.

Do not use substances such as WD-40, silicone sprays, oil or grease on bearings or on flanges.

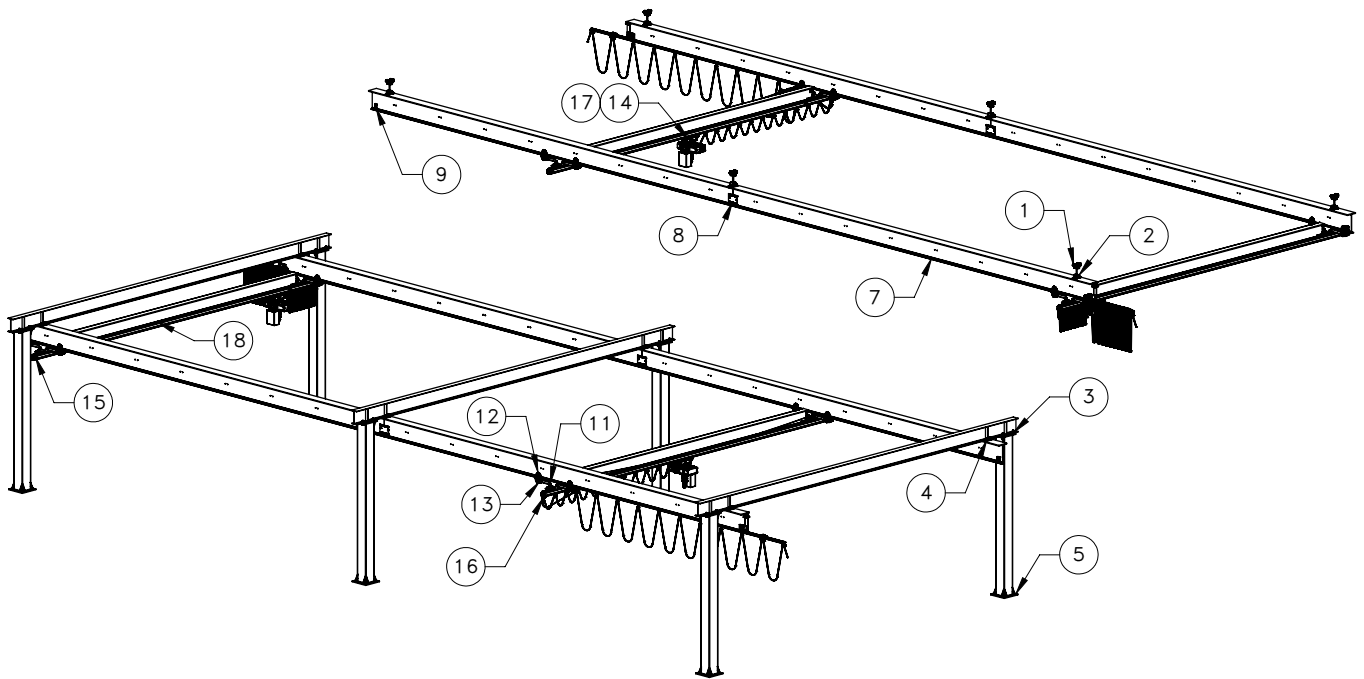

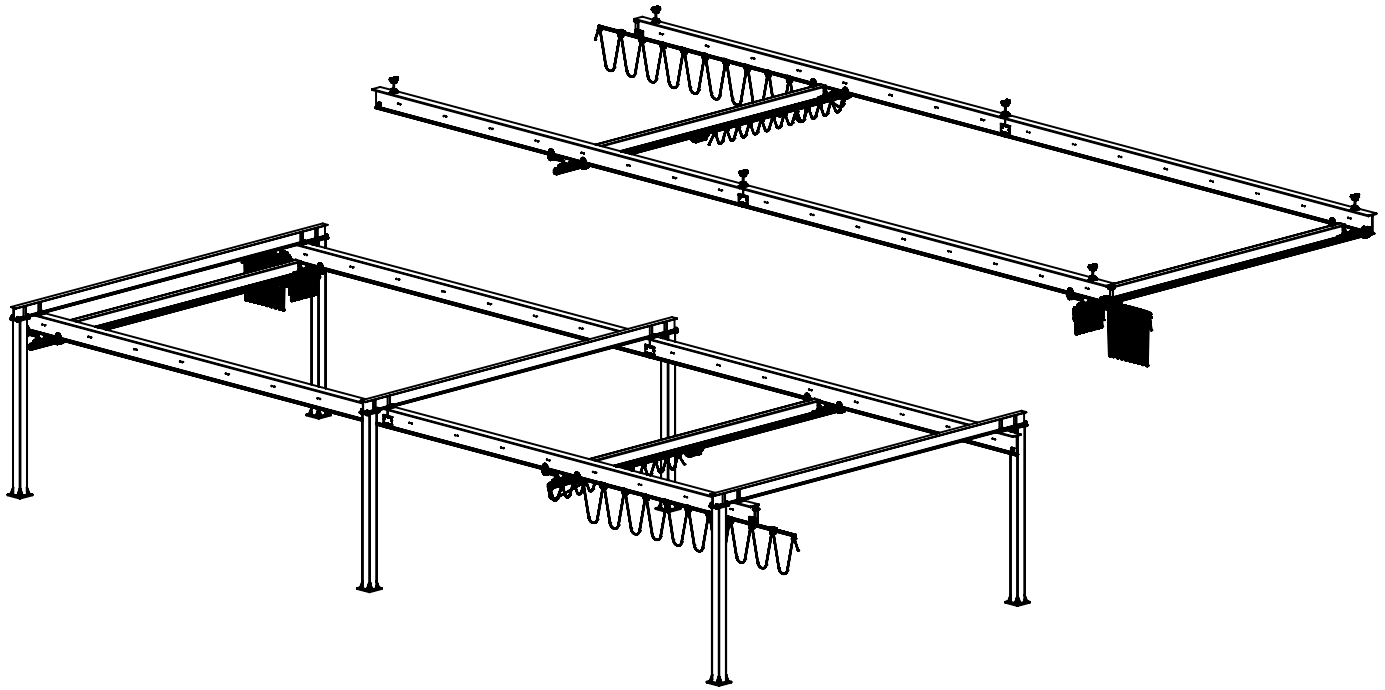

⚠ WARNING

This product contains chemicals known to the State of California to cause cancer and birth defects or other reproductive harm.

For more information: www.P65Warnings.ca.gov

GORBEL®
A CLASS ABOVE

600 Fishers Run, P.O. Box 593
Fishers, NY 14453-0593
Phone: (800) 821-0086
Fax: (800) 828-1808
E-Mail: info@gorbel.com
<http://www.gorbel.com>
©2010 Gorbel, Inc.
All Rights Reserved

